

# **Model Yachting**

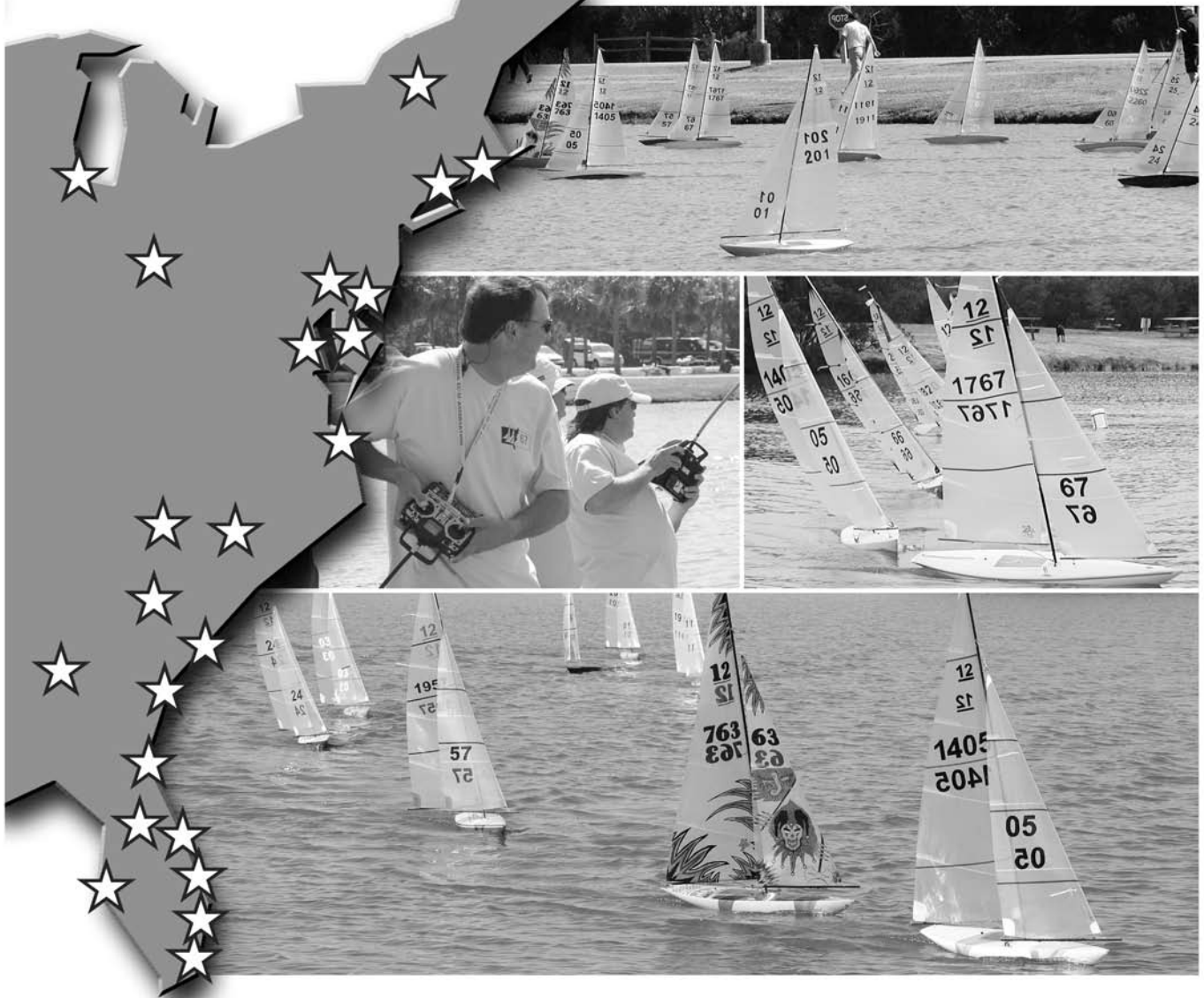
A Quarterly Publication of the American Model Yachting Association, Special Web Past Issue, from 2005, Issue Number 138

US\$7.00

***Special  
Web Edition  
Featuring  
Hardware  
& Rigging***



# EC-12



*No other class offers as much competition*

With over 20 two-day regattas each year and averages of more than 25 boats per event, the EC-12 is in a class by itself. If competitive racing action and interaction with others is what you're after. Look no further than the East Coast 12-Meter.

One quick glance of the AMYA's regatta schedule page at [www.amya.org/regattaschedule/racelist.html](http://www.amya.org/regattaschedule/racelist.html) and you will see that no other class offers as much racing opportunities. There is probably a regatta coming to a lake near you. We invite you to come out a see for yourself how exciting the action is and how much fun you can have in model yachting.

**[www.ec12.org](http://www.ec12.org)**

[www.ec12.org/Clubhouse/Discussion.htm](http://www.ec12.org/Clubhouse/Discussion.htm) • [www.ec12.org/Clubhouse/12Net.htm](http://www.ec12.org/Clubhouse/12Net.htm)

## On the Cover

The Front Cover is a photo of Rich Matt's spinnaker driven AC boat; photo by Rich Matt. Rich's article about "Spinnaker Adventures" is a great lead article for this issue.

This special Web Feature issue of *Model Yachting Magazine* features ideas for Hardware and Rigging of your model yachts. As with all our Class Features issues, there are many examples of ideas for a specific classes that are applicable to all classes.

The American Model Yachting Association (AMYA) is a not-for-profit organization dedicated to promoting the designing, building, racing, and preservation of all model sailing yachts and is open to all people who are interested in these activities.

In pursuit of these goals, the AMYA publishes Model Yachting magazine. Model Yachting is published four times per year in accordance with the AMYA calendar. The staff of the magazine is composed primarily of AMYA member volunteers who devote countless hours of their time to produce this publication. Editorial policy is ultimately determined by the AMYA Board of Directors; however, the views expressed in this publication do not necessarily represent the views of the Executive Board, the Board of Directors, or the majority of the AMYA membership.

Advertising in this publication is encouraged as an informative service to the AMYA members and as a means of helping defray the costs of printing. The AMYA does not take any responsibility for any advertiser's products.

This issue of Model Yachting, except those parts as are specifically stated, is Copyright © 2005 by the American Model Yachting Association, June 2005. All rights reserved.

## Advertiser Index

Anchor Bay Specialties	36
American-RC.com	9
Black Sails	37
Carr Sails	15
Chesapeake Performance Models	32
Dennis Desprois' Walrus Sails	15
EC12 Association	2
Hanna Boats	39
Hitec	38
Isobar	58
Leading Edge Hobbies	24
Midwest Model Yachting	17
Model Yacht Fittings	16
R/C Concepts	35
RMD Marine	58
RMG Sailwinch	16
Scale Sailing	17
Tell-tale	9
Traplett	59
US 12 and Liberty	34 44
Victor Model Products	54
Windjammin Sails	48



## Contents of this Special Web Edition, Past Issue 138

The Masthead .....	4
President's Introduction Letter .....	5
Editorial Calendar .....	5
Model Yachting News .....	6
Business Calendar .....	6
<b>Special Features—Hardware &amp; Rigging:</b>	
Spinnaker Adventures .....	7
Rotating Wing Mast on a 10R .....	18
Ball Bearing Goosneck for the Wing Mast .....	21
Fittings .....	22
Goosneck and Vang Construction .....	24
Backstay Tensioner & Traveler .....	26
Single Channel SCU with Jib Trim .....	27
Hardware and Rigging .....	28
Skalpel Running Rigging .....	33
<b>Additional Hardware Articles from Other Issues:</b>	
From 135: Single Channel Sail Control with Main Sheet Fine Tuning .....	40
From 142: The Spektrum DX6 R/C System .....	42
From 149: Modifying a Spektrum DX6 Transmitter .....	46
From 148: Soling One Meter Construction Tips .....	49
From 148: A Drum Winch for Your Soling One Meter .....	52
From 149: ODOM Tips, Tricks, and Techniques .....	55
<b>Regatta Reports (Not included)</b>	
<b>Regatta Schedule (Not included)</b>	
<b>Class Views &amp; Tips (Not included)</b>	
<b>AMYA Business:</b>	
AMYA Stats & Facts .....	60
AMYA Yacht Registration Form .....	60
AMYA Ship's Store Order Form .....	61
AMYA Membership Application Form .....	62

**Join the AMYA and get Model Yachting magazine! Your Membership Application is on Page 61.**

06-20-06

**AMYA's newest & smallest class.**

This 3 1/2" x 2" border is the size of our Business Card ad. Cost per issue \$40.00. Contact myAdvertising@ModelYacht.org for details.

# The Masthead

## EXECUTIVE BOARD

President Pete Maxson  
 Vice President Chuck Buzek  
 Treasurer Gene Faust

## REGIONAL DIRECTORS

Region 1 Ken Shaw  
 Associate Director Chuck Luscomb  
 Region 2 Alan Sellers  
 Region 3 Jack Wubbe  
 Region 4 Frank Vella  
 Associate Director Dick Martin  
 Associate Director Tony Johnson  
 Region 5 John Hanks III  
 Associate Director Larry Ludwig  
 Region 6 Bob Eger

## AMYA STAFF

Executive Secretary John Hanks III

Membership Sec'y Michelle Dannenhoffer  
 Ship's Store Michelle Dannenhoffer  
 Historian Paul Meskill  
 Manufacturer Rep Paul Meskill  
 Regatta Coordinator Doug Hemingway

Webmaster Philip Sarelis  
 Honest Ahab Ads [open]  
 Marketing Director Ralph Templin  
 Show Coordinator and Media Rep

## MODEL YACHTING EDITORS & COLUMNISTS

Editor John Davis  
 Class Features Carroll Bures  
 Class News Rich Ellis  
 Regatta Reports Doug Hemingway  
 Copy Pat Butterworth  
 Copy Associate Bruce Crichton  
 Copy Associate Bob Henrickson  
 Copy Associate Bill Young  
 Photo Rich Matt  
 Technical Dick Lemke  
 Illustration Jim Linville  
 Advertising Paul Meskill  
 Racing Rules Bill Worrall  
 Cartoons Ralph Kanko  
 US Vintage MYG Earl Boebert  
 European Klaus Huber

## CLASS SECRETARIES

EC 12 Meter Rick West  
 Santa Barbara Ernie Mortensen  
 Marblehead Standley Goodwin  
 10-Rater Mark Gee  
 36/600 Jay Barnes  
 Newport 12 Meter John Hanna  
 Open Bill Young  
 Star 45 Don Keeney  
 J John Hanks III  
 Soling 50 Stan Ogden  
 US One Meter Jim Linville  
 Infinity 54 Jim Hensel  
 AC Larry Rapp  
 Soling One Meter Paul Fixx  
 CR 914 Dick Martin  
 ODOM Bill Mullica  
 Traditional 36 Jay Barnes  
 Victoria Brian Roberts  
 Wheeler Jim Mayne  
 RC Laser Steve Lang  
 Int'l One Meter Steve Landeau  
 V-32 Paul Thompson  
 Fairwind Kerry Pebbles  
 SeaWind Mike Eades  
 US 12 Jack Ward  
 Footy Bill Hagerup

## SPECIAL INTEREST GROUP, US VINTAGE MODEL YACHT GROUP

President John Snow

Contacts for questions regarding overall operation of the AMYA:

5917 Brockport-Spencerport Road, Brockport NY 14420 585-637-3603  
 P.O. Box 2353, New Smyrna Beach FL 32170 386-423-5863  
 67 Glenwood Drive, Webster NY 14580 585-671-5897

Contact Region Directors or Associates for questions or issues regarding your club or the region:

36 Greenwood Avenue, Essex Junction VT 05452-4116 802-872-9990  
 34 Elm Street, Deep River CT 06417 860-526-4676  
 3801 Macalpine Road, Ellicott City MD 21042-5214 410-750-7783  
 359 Bay Forest Drive, Naples FL 34110 239-591-1345  
 3670 Seymour Lakes Drive, Ortonville MI 48462 248-627-8060  
 1206 Castle Bay Place, Columbia MO 65203 573-256-7213  
 80 Florence Drive, Excelsior MN 55331-8538 952-474-9715  
 1849 Rainbow Ave South, Lake Havasu City AZ 86403 928-680-7331  
 2906 Wakeman, San Antonio TX 78247 210-724-3827  
 1322 Las Palmas Drive, Santa Clara CA 95051 408-247-0860

president@ModelYacht.org  
 vicePresident@ModelYacht.org  
 treasurer@ModelYacht.org  
 region-1@ModelYacht.org  
 region-1ct@ModelYacht.org  
 region-2@ModelYacht.org  
 region-3@ModelYacht.org  
 region-4@ModelYacht.org  
 region-4mo@ModelYacht.org  
 region-4mn@ModelYacht.org  
 region-5@ModelYacht.org  
 region-5tx@ModelYacht.org  
 region-6@ModelYacht.org

Contact Executive Secretary for new club sanctioning, motions, nominations, and votes:

1849 Rainbow Ave South, Lake Havasu City AZ 86403 928-680-7331 executiveSec@ModelYacht.org

Contact for address changes, problems with addresses, magazine delivery, memberships. Ordering Ship's Store items:

P. O. Box 360374, Melbourne FL 32936 888-237-9524 or 321-254-7107 membership@ModelYacht.org  
 P. O. Box 360374, Melbourne FL 32936 800-420-3048 or 321-254-7108 shipsStore@ModelYacht.org  
 158 State Route 70, Arkport NY 14807 607-545-6277 historian@ModelYacht.org  
 158 State Route 70, Arkport NY 14807 607-545-6277 manufacturerRep@ModelYacht.org  
 5683 Lewiston Road, Middleport NY 14105 716-735-9919 regatta@ModelYacht.org

Contact Webmaster for all information regarding the AMYA website, including changes, corrections and links:

304 W. 1st North Street, Laingsburg MI 48848-9661 517-651-2628 webmaster@ModelYacht.org  
 Contact the President about this assignment myHonestAhab@ModelYacht.org  
 419 Dewey Street, Royal Oak MI 48067 586-630-8165 marketing@ModelYacht.org  
 Contact the President about these assignments

Contacts for all information about Model Yachting Magazine, article, photo and ad submissions:

6813 Aubrey Court, Johnston IA 50131 515-334-8001 myEditor@ModelYacht.org  
 51 Lee Shore Lane, Tiverton RI 02878 401-816-0172 myClassFeatures@ModelYacht.org  
 4 Golf Lane, Hebron CT 06248 860-228-3327 myClassNews@ModelYacht.org  
 5683 Lewiston Road, Middleport NY 14105 716-735-9919 myRegattaReport@ModelYacht.org  
 8 Hampshire Road, Wellesley MA 02481-2832 781-235-1644 myCopy@ModelYacht.org  
 13031 Shallowater Road, Jacksonville FL 32258-8435 904-262-1574 myCopyAssoc@ModelYacht.org  
 264 Burke Road, Lexington KY 40511 859-252-9334 myCopyAssoc2@ModelYacht.org  
 1962 Cliffrose Drive, Lake Havasu City AZ 86403 928-415-0293 myCopyAssoc3@ModelYacht.org  
 207 Briarwood Pass, Oak Brook IL 60523 630-654-1569 RichMatt@comcast.net  
 1460 - 17th Street West, Hastings MN 55033 651-437-6852 (After 7:30 PM) myTechnical@ModelYacht.org  
 57 Edgewater Road, Hull MA 02045 781-925-0045 jimisu@comcast.net  
 158 State Route 70, Arkport NY 14807 607-545-6277 myAdvertising@ModelYacht.org  
 626 Nuevo Leon Lane, The Villages FL 32159 352-753-0057 myRacingRules@ModelYacht.org  
 6556 Durban Road, Dayton OH 45459 937-436-3677 myCartoons@ModelYacht.org  
 9219 Flushing Meadows NE, Albuquerque NM 87111 505-823-1046 vintage@ModelYacht.org  
 Therese-Giehse-Allee 46, 81739 Muenchen, Germany (11) +49 89 6379352 myEuropean@ModelYacht.org

Contacts for all information about yacht classes rules, championship events, and class business in general:

139 Dardenelle Avenue, Pacifica CA 94044 650-359-1525 ec12@ModelYacht.org  
 6236 Cardeno Drive, La Jolla CA 92037 858-729-0084 santabarbara@ModelYacht.org  
 33 Norman Street, Marblehead MA 01945 781-631-5847 marblehead@ModelYacht.org  
 8032 E. Inspiration Drive, Parker CO 80138 303-805-7881 10r@ModelYacht.org  
 1105 Tonapah Drive, Cottonwood AZ 86326 928-634-3448 36600@ModelYacht.org  
 6809 Silver Chisel Avenue, Las Vegas NV 89130 702-767-2639 newport12@ModelYacht.org  
 1962 Cliffrose Drive, Lake Havasu City AZ 86403 928-415-0293 open@ModelYacht.org  
 598 Roselea Drive, Buchanan Dam TX 78609-2557 512-793-5906 star45@ModelYacht.org  
 1849 Rainbow Ave South, Lake Havasu City AZ 86403 928-680-7331 j@ModelYacht.org  
 17140 Advantage Point, Bakersfield CA 93306 661-871-2510 soling50@ModelYacht.org  
 57 Edgewater Road, Hull MA 02045 781-925-0045 us1m@ModelYacht.org  
 168 Springdale Way, Emerald Hills CA 94062 650-365-3085 infinity54@ModelYacht.org  
 4053 Antique Lane, Bloomfield Hills MI 48302 248-855-8734 ac@ModelYacht.org  
 P.O. Box 27, East Hardwick VT 05836 802-472-6569 soling1m@ModelYacht.org  
 1206 Castle Bay Place, Columbia MO 65203 573-256-7213 cr914@ModelYacht.org  
 18069 Sawmill Road, Colorado Springs CO 80908 719-488-6524 odom@ModelYacht.org  
 1105 Tonapah Drive, Cottonwood AZ 86326 928-634-3448 traditional36@ModelYacht.org  
 2323 Stryker Avenue, Vienna VA 22181 703-281-9310 victoria@ModelYacht.org  
 20 Russell Road SP 48, Salinas CA 93906 831-449-3204 wheeler@ModelYacht.org  
 290 Circle Drive, Evergreen CO 80439 303-670-4670 rcLaser@ModelYacht.org  
 3735 W. Sheringham Avenue, Orange CA 92868 714-939-9037 iom@ModelYacht.org  
 6823 Shore Island Drive, Indianapolis IN 46220 317-254-0156 v-32@ModelYacht.org  
 15031 Lakewood, Plymouth MI 48170 734-420-4405 fairwind@ModelYacht.org  
 2090 Middle Mesa Drive, Wickenburg AZ 85390 928-684-5624 seawind@ModelYacht.org  
 26160 Feathersound Drive, Punta Gorda FL 33955 941-575-1183 us12@ModelYacht.org  
 431 Sheridan Road, Moultonboro NH 03254 603-284-6642 footy@ModelYacht.org

# An Introduction to this Special Issue



Pete Maxson, AMYA President  
president@modelyacht.org

Many of you have downloaded this free Acrobat document in hopes of learning more about model yachting. That's great! You came to the right site when you came to the American Model Yachting

Association (AMYA). We have placed the technical content in this issue of our quarterly *Model Yachting* magazine on our website with the hope of convincing you to join us in our efforts to promote model yachting. In addition to four quarterly issues of *Model Yachting*, all new members receive our latest Getting Started Issue, which explains many of the basics of radio controlled model yachts and introduces the model yacht classes we sanction. Our Editorial Calendar for upcoming features is shown at the bottom of this page.

We promote and sponsor over 25 different classes of model yachts, which range in size from 12 inches (the Footy) to 8 feet (the majestic J boats). This assures that there will be a boat just the right size to meet your needs and wants. There are kits for many of the classes and plans for many, too, so if you are not a model maker, you can still be a model sailor.

We also promote the camaraderie of sailing. When traveling, many of our members will look for clubs near their destinations and contact members to make plans to meet at the pond, or at least gather some information about local sights and activities that may not be well known to the casual visitor. I found a great restaurant in Squam, Washington, this way"

The AMYA is a group of people who have organized themselves as a fraternity of members who are interested in all aspects of model yachting in the US, as well as internationally. US SAILING, the national governing body of sailing in the US, recognizes us as

the governing body for US model yachting activity. Like most governing bodies of model yachting around the world, we use the internationally recognized Racing Rules of Sailing, including the US Sailing Prescriptions, to organize and regulate our racing events. We make the necessary rules to regulate ourselves through our By Laws (which can be found on our website).

Officers elected by our members govern the AMYA. Secretaries elected by members of each class of boat govern the classes. We have established policies and procedures for recognizing sanctioned classes, changing class rules, and providing a structure to handle disputes. We sanction clubs and provide them with what is essentially a national referral service. A large body of our clubs and members are focused on r/c model yacht racing, but we are not solely interested in racing. Many of our members are interested in vintage models, operating scale models, and free-sailing models that have no radio control at all. We encourage and promote model yachting in all of its rich variety.

The AMYA promotes model yachting to the hobby industry, and our growth in membership has a very real impact on the availability of products developed for model yachts. We do appreciate every new and continuing member. The current hobby industry considers model yachting as a *marginal* market group. By joining the AMYA and increasing our numbers, you are directly changing the perception of the hobby industry and encouraging them to produce more products specifically for use in model yachting.

A staff of over 60 volunteers runs the AMYA. We are constantly trying to stay abreast of modern technology and use it for the benefit of our members. We are only as good as our membership makes us. So, come on board and join the group! Learn a lot! Meet new friends! Help us become a better organization.

*See you at the pond.*



## Editorial Calendar & Schedule Magazine Deadlines for 2008-2009

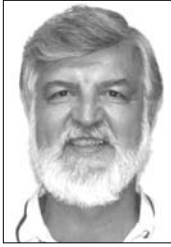
**Definition of Deadline:** The *Deadline* is the last date for each Editor to *Receive* submitted material.

Adhering to deadlines is a *necessity* to be able to *deliver on schedule*. Deadlines are *the final due dates*.

\*The delivery date for Issues to members with the USA First Class Option is four to eight weeks sooner than the standard membership.

Planned Editorial Calendar	Special & Featured Class Articles & Photos	Magazine Photos & Ad	Final Magazine Articles & News	Issue Printed & *Approximate Delivery:
Issue/Featured Class or Special Feature:	Deadline:	Deadline:	Deadline:	
151 / Special: 75th Anniversary of Marblehead	Nov 6, 2007	Dec 6, 2007	Dec 26, 2007	Spring 2008 - Feb/Mar
152 / Footy Class	Feb 6, 2008	Mar 6, 2008	Mar 26, 2008	Summer 2008 - May/Jun
153 / CR 914 Class	May 6, 2008	Jun 6, 2008	Jun 26, 2008	Fall 2008 - Aug/Sept
154 / R/C Laser Class	Aug 6, 2008	Sep 6, 2008	Sep 26, 2008	Winter 2008 - Nov/Dec
155 / Special: European Model Yachting	Nov 6, 2008	Dec 6, 2008	Dec 26, 2008	Spring 2009 - Feb/Mar
156 / J Class	Feb 6, 2009	Mar 6, 2009	Mar 26, 2009	Summer 2009 - May/Jun
157 / Soling 50 Class	May 6, 2009	Jun 6, 2009	Jun 26, 2009	Fall 2009 - Aug/Sep
158 / US 12 Class	Aug 6, 2009	Sep 6, 2009	Sep 26, 2009	Winter 2009 - Nov/Dec

# Model Yachting News—An Introduction



by John Davis, Editor  
myEditor@modelyacht.org

Welcome to our Web Issue 138 of *Model Yachting* magazine, and welcome to the AMYA. This Hardware and Rigging Issue, a Special Edition for the AMYA website, is about gaining an understanding of what you can expect to find in issues of *Model Yachting* as an AMYA member. Our goal with this special edition is to offer you a good reason to join the AMYA, and get every quarterly issue of *Model Yachting* magazine.

This sample issue will be revised on a regular basis to assure the Masthead, listing our Officers; our Ship's Store Order Form; and our Membership Application are current and up-to-date. Similarly, ads have been revised to reflect our current suppliers. The Business and Deadline Calendar below lists dates of magazine deadlines, but not the actual planned feature for each issue. We have not included the Regatta Reports column, the Racing Rules column, or the Class Views & Tips column. This sample includes the technical articles found in the original Issue 138 and a few additional articles from other issues, so you can get an idea of the quality of content in *Model Yachting* magazine.

*Model Yachting* is the official quarterly publication of the AMYA. It generally has the same look you see in this Special Feature issue. In fact, some

of the graphic style has been updated from the original (2005), to match our current (2008) style. Running about 60 pages, each issue is packed with as much information and photos as we can include. We do pay for art production, printing, and mailing production, but like most endeavors of the AMYA, the staff and writers of *Model Yachting* are volunteers. Model yachting enthusiasts, sharing knowledge of our pastime, hobby, and sport, do the heart and soul of this work.

We share significant information on our website in the form of MY Downloads, found in the *Model Yachting* magazine part of the website. We also post the past four issues of the Class Views and Tips section, so class members may be aware of recent class business and technical tips. In fact, this information is posted before the magazine is actually printed and mailed.

We encourage you to find a place in our pastime and have a good time. As an organization, we exist to help each other get more fun out of this than we could if we were isolated sailors. We encourage you to encourage others. We were all beginners once, not knowing what kind of gooseneck to install, nor even what a goose is doing on a model yacht.

Every three or four years, we print a Special Feature Issue titled Getting Started. This issue offers up-to-date information that is especially useful to beginning skippers. We distribute this to our members, and every new member gets a copy when joining the AMYA. We try to fully cover the basics in this is-

sue, but know we cannot answer all your questions. Search the vast resources of the Internet (starting with [www.ModelYacht.org](http://www.ModelYacht.org)), the books about model yachting, and the resources of your local club; and you will learn. We expect some day you will be writing for this magazine, helping someone else gain the knowledge that you have learned—that is what we are about.

In any given year, usually three of our four issues are dedicated to a specific class and are referred to in the Deadline Calendar as Featured Classes. The work of coordination and recruiting authors for these issues is done by the Class Secretary of that featured class, with *Model Yachting* staff members assisting in whichever ways needed. Some of these articles are class specific, but most of the material is applicable to all model yachts, and of interest even if the featured class is not your favorite.

The fourth quarterly issue is dedicated to a more general, or topical, subject such as Hardware and Rigging, or Getting Started. These special features add variety and interest to the format of *Model Yachting*. Much of our content is directed to racing, but the AMYA is not simply a racing organization, and our magazine reflects our varied model yachting interests—vintage, semi-scale, racing, local, national, and international.

Model yachting, like big-boat sailing, offers a lifetime of friends to enjoy, challenging skills to develop, fun boats to build (or buy built), and sail, and race, and gain great personal satisfaction.

*Fair winds to you and yours.*

## AMYA Business and Model Yachting Deadline Calendar

November	6	Deadline for Featured Class or Special Feature articles and photos for Model Yachting, Spring Issue.
December	6	Deadline for Ads to Advertising Editor and Photos to Photo Editor, going into Model Yachting, Spring Issue.
December	26	Final Deadline for all articles, Class Views, Regatta Reports to be included in Model Yachting, Spring Issue. *Delivers in February.
February	6	Deadline for Featured Class articles and photos for Model Yachting, Summer & Ballot Issue.
<b>March</b>	<b>3</b>	<b>Deadline for submission of all Nominations and Motions for the 2007 Ballot, to the AMYA Executive Secretary.</b>
March	6	Deadline for Ads to Advertising Editor and Photos to Photo Editor, going into Model Yachting, Summer Issue.
March	26	Final Deadline for all articles, Class Views, Regatta Reports to be included in Model Yachting, Summer Issue. *Delivers in May.
May	6	Deadline for Featured Class articles and photos for Model Yachting, Fall Issue.
June	6	Deadline for Ads to Advertising Editor and Photos to Photo Editor, going into Model Yachting, Fall Issue.
June	26	Final Deadline for all articles, Class Views, Regatta Reports to be included in Model Yachting, Fall Issue. *Delivers in August.
August	6	Deadline for the Featured Class articles and photos for Model Yachting, Winter Issue.
September	6	Deadline for Ads to Advertising Editor and Photos to Photo Editor, going into Model Yachting, Winter Issue.
September	26	Final Deadline for all articles, Class Views, Regatta Reports to be included in Model Yachting, Winter Issue. *Delivers in November.
<b>September</b>	<b>30</b>	<b>Deadline for 2006 Ballot's to be received by the AMYA Executive Secretary. Voting results in Winter Issue.</b>

\*Delivery is based on the membership option for First Class Delivery. Normal Fourth Class delivery is unpredictable.

# Spinnaker Adventures



*The first of Rich Matt's spinnaker boats. A mid-1970 LJ-50 Marblehead, or "50/800" as we called them back then. M-Class rules once allowed a 15" spinnaker pole making for an oversize "chute". Having a large open hatch in the bow into which the spinnaker was retracted, and not fitted out with a self-draining stowage compartment in which to stow the spinnaker, this boat now, as for the past thirty years "sleeps with the fishes" in Axehead Lake, Chicago. Photo by Bud Salika.*

by Rich Matt

Over the years there have been a few of us model boat sailors that have experimented with devices that would hoist, set and then retract a spinnaker by R/C. Motivation probably came mostly from the fun of figuring out how to get the mechanical things working right and to learn if a spinnaker provided any real advantages when racing. As a carry over from vane sailing days and up until about the 1990's, the Marblehead and Ten-Rater classes allowed spinnakers. Today these two classes have changed their mind and now disallow them. My first spinnaker-equipped boat years ago was an LJ-50 M, the second was an Epic M, and following that was a Ten-Rater. These three boats taught me the ropes (lines) involved with a hoisting and retracting system. Although the boats had been entered and sailed in regatta events,



*Learning a lesson from the LJ-50, this late 1970's Epic-M was outfitted with a servo operated opening and closing bow hatch. After earning a second place trophy at a regatta in Tampa, Fl; a fourth place at an M-Class Annual Championship regatta held in DesMoines, Iowa; and often sailed in club races; this boat stayed afloat long-enough to realize safe retirement on a closet shelf in Chicago, IL. Most photo's by Rich Matt.*

I will admit I never realized any significant improvements in my race results. If nothing else, a spinnaker being hoisted or lowered (successfully or unsuccessfully) did do wonders to distract the competition and at the same time entertain the spectator crowd.

Today the 36/600 and AC are the only AMYA classes permitting spinnakers. Because of its small hull size, rigging a retractable spinnaker on a 36/600 might be a real trick; but perhaps somebody out there is working on it. On the other hand, the AC is a big boat that can readily accommodate the installation of all the mechanical stuff involved with a spinnaker hoist and retract system. A few years ago I first saw an AC out on the pond and could not help but think of a variation to the famous quote made by Crocodile Dundee, "Now, this is what I call



*This spinnaker-equipped Ten-Rater was put together purposely for a World's Championship Regatta held 1980 in Ottawa, Canada. On this, its first public appearance, it failed miserably. On only one leg of the entire course for the entire duration of the three-day event did the wind come with some consistency from directly downwind. Also, all other traffic was way far ahead out of the way. Finally, it was right to hoist the spinnaker. Spinnaker went up, spinnaker flew, and spinnaker was retracted. The half-dozen sailors from Japan gave a polite round of applause. Rather than take this boat back home, I passed it on to friend Henry Morris who took it with him to Newark, DE.*

a boat". Almost seven feet long, over nine feet tall, weighing a couple dozen pounds and sailing along as if it were the proverbial "Speeding Locomotive" all meant that I wanted to own one for myself. A Boogieman AC hull came available and I went for it. Not long after putting the boat together and sailing it a few times my long-dormant spinnaker fantasies kicked in once again. Just recently, after mixing together the experiences of years ago along with a lot of new trial and error towards working out the bugs, I think I now have with this boat a spinnaker installation that works with some degree of reliability.



*Here's the boat described in this article. It's an AC, one of two classes in all of AMYA that provide for spinnakers. One hand on the transmitter and with the other hand on the camera, this photo was taken last fall one week before the pond froze over. Main and jib need to be eased out. Also, since then both spinnaker pole and spinnaker afterguy have been shortened a couple inches so that the spinnaker will be drawn close to the clevis on the end of the pole.*

It needs to be mentioned that there are two varieties of spinnakers to choose from, symmetrical and asymmetrical. Fellow Chicago club member, Gary Mueller, has installed on his AC a hoist-retract system for an asymmetrical spinnaker. This version of a spinnaker is tacked to the boat's bow and does not use a pole for setting the spinnaker out to weather. The asymmetrical spinnaker almost resembles a huge, balloon-like Genoa jib. Full-size IAC Class boats are using asymmetrical spinnakers because tacking downwind, going from broad reach and gybing over to broad reach, makes for greatest speed to the downwind mark. On the other hand, the more traditional symmetrical spinnaker that I chose to go with uses a pole attached to the mast and is intended for sailing a more directly downwind course rather than a broad reaching course. It could be argued that model boats, unlike some full-scale boats, do best by sailing downwind directly towards the mark, and that is why I went with the symmetrical. In time we will find out



*Gary Mueller, respected all over USA as a master model boat craftsman as well as a being a very competitive sailor, outfitted his AC with an asymmetrical spinnaker. Tacked to the bow and hoisted to the masthead, it makes for one very big sail. Three custom long-travel RMG 380 winches are employed to hoist, retract and gybe this spinnaker. Gary is now installing some refinements to the system, and it should be ready and raring to go soon. Photo by Rich Smentek.*

how our two boats compare.

#### **ISAF RRS Rule. 50.2**

The AMYA AC Class makes no significant exceptions or modifications to the full-scale IAC Class measurement specs or, just as importantly, the ISAF Racing Rules of Sailing. Racing Rules of Sailing, Part 4, Rule 50.2 reads: Only one spinnaker pole shall be used at a time except when gybing." This precludes any thought of flying a spinnaker while using two poles. On a model boat it might be advantageous to set a small narrow spinnaker using two poles and then be able to gybe whenever opportune and without fuss. But, on a people-

boat using two poles at the same time might be dangerous and is probably why the one-pole rule. If the leeward pole were ever to be dunked during a knockdown, all kinds of bad things might happen. Two poles being used when gybing, even when allowed per the rule, would no longer provide the bowman with a leeward side of the headstay as a shield during a gybing maneuver. Seldom do you see a peopleboat even having two poles chocked on deck – The extra pole is not used and it is extra weight. Therefore, since there is no mention of two poles being allowed when flying a spinnaker in the AMYA AC Class Rules, it is to be as-



sumed that Racing Rule 50.2 applies.

An additional mechanical device operating off another servo function could be designed to hoist one pole and lower the other so as to gybe the spinnaker in accordance with Rule 50.2. But, when gybing there remains the problem of taking the spinnaker afterguy that runs through the outer end of one pole and swapping it with the spinnaker sheet which runs free of the other pole. Fellow peopleboat sailors are probably thinking that there might be a way of doing it by using a double, or “lazy-guy”, along with a double, or “lazy-sheet”. When gybing the spinnaker on peopleboats the crew douses the jib and clears the foredeck so that the spinnaker sheet and spinnaker afterguy are exchanged with one another as the single pole is swung across inside the open fore-triangle. On an R/C boat the jib remains up in place and is in the way of swinging the pole and will interfere with leading the spinnaker sheet and afterguy. Devising a method for gybing a single pole will probably occur to someone, someday. For me and for now, just getting the spinnaker up and down with some reliability is enough of a project.

There are two proprietary one-design classes of boats available from microSAIL!, the America One and the Spinnaker 50, having working spinnakers that are flown using two poles. Being one-design classes, their own rules and measurement specs can be written to accommodate the two poles as an exception to Rule 50.2. Doug Lord's [www.microsail.com](http://www.microsail.com) website provides photos and a description of the microSAIL! two-pole system.

### Reaching

Then too, gybing a spinnaker by R/C while in traffic and rounding the



*Doug Lord's spinnaker equipped one-design, America One, should someday soon achieve AMYA sanctioned class status. This clever two-pole, ready gybe-able spinnaker retracts belowdeck into a self-bailing stowage tube. The Spinnaker 50 is another boat available from Doug that has the same spinnaker system. Learn more about both boats from his website: [www.microSAIL.com](http://www.microSAIL.com).*

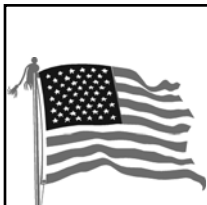
far-off hard-to-see “wing” mark seems to me to be a way of ramping up the risk of being protested. Keep in mind that the typical parade to and around the reaching mark often turns out to be more a test of eyesight and depth perception than a test of sailing skill. Visibility is one concern, maintaining good steering control while reaching under spinnaker is another. Reaching will involve near continuous trimming of the spinnaker to keep it full and flying while at the same time steering the

boat on course.

At most every regatta, one tack or the other on the downwind legs always seems to be favored. It is an easy matter to preset the pole to be on port or starboard tack while the boat is on shore before or between races. All you need do is to exchange the spinnaker sheet for the afterguy through the clevis on the end of the pole.

There is another consideration that contributes to the decision as to which tack the pole should be set. You need to keep in mind that after rounding the weather mark, and before hoisting the spinnaker, you want to position yourself on the downwind leg to be the most leeward boat. After all, it is great fun for a leeward boat without spinnaker, but having luffing rights, to be overtaken by a boat to weather that's flying a spinnaker. There will be an irresistible reaction by the leeward boat without spinnaker to luff up quickly and cause the weather boat's spinnaker to collapse or even be backwinded against the mast. With spinnaker, sailing low is the way to go.

It would not be difficult to design a mechanism and use an extra channel for easing the afterguy while trimming the spinnaker sheet. Easing the pole forward while trimming the sheet aft would allow the symmetrical spinnaker to be carried higher on a broad reach as well as on a run. Ideal for the job would be a self-centering swinging arm sail control with lines led to the shackles on the spinnaker's aft turning blocks. Easing one block forward while drawing the other block aft would provide the desired trimming effect. It would take some practice to both steer a proper course and at the same time work spinnaker trim so that it stays full and flying. Instead of installing a trim device, a spinnaker can

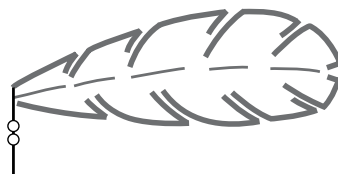


## American-RC.Com

Specializing in Kyosho Yachts  
Lansing, Michigan

517-651-BOAT (2628)

Kits, Batteries, Chargers, Radios, Hulls  
We Build, Race, and Service What We Sell



**Tell-tale**  
red, orange  
or yellow

Large, bright, light feather

Send check for \$15 each plus \$5 shipping and handling to:  
W. Lynders, 369 Fairview Avenue, Fairfield, CT 06824



be designed having narrow shoulders that will allow the spinnaker to stay full even when on a broad reach.

### Spinnaker Dimensions

On an R/C boat the size of the spinnaker is an important factor. A big spinnaker is hard to fill in light winds because of its own weight. Hoisting a big spinnaker in strong winds invites the opportunity for an exciting and crowd pleasing broach. A spin-out broach to weather does wonders for getting nearby boats to

luff up and scatter for their lives. A gybing spin-out to leeward where the boat does a full turn and pirouettes around the dunked spinnaker pole is always a good show. Being dragged sideways off the course under a big spinnaker in a permanent knockdown with the rudder frantically waving in the breeze is not the fastest way of getting to the next mark. Then too, a big spinnaker up in a good wind will increase the boat's tendency to submarine. On the other hand, a spinnaker that's too small will not look right nor will it add

all that much boatspeed.

Dimensions of the boat's rigging will determine the size of the spinnaker. The space between where the pole is "goosenecked" to the mast and up to where the jibstay fitting is attached will determine the length of the spinnaker luff. A couple more inches are added to this luff measurement so as to provide a forward curving balloon shape to the flying spinnaker. The length of the pole and the half-circle circumference of the spinnaker as it goes forward around the forestay

and back around behind the jib will determine the spinnaker's foot measurement. Measurements for my AC-32's spinnaker come to 55" on the luff and 36" on the foot. The pole is 18.5" long. When it comes time to replace this spinnaker I plan on adding about 3" to the foot measurement in the interest of appearance and to project the spinnaker foot a bit further forward away from the jibstay.

When flying, the spinnaker is positioned roughly up from the deck about one-fourth the length of the mast and about one-fourth lower than the top of the mast. This puts the spinnaker up away from the disturbed wind at deck level and down from the masthead where the spinnaker is less likely to affect steering control. This also puts the flying spinnaker up at a level where only the narrow upper half of the jib might blanket airflow. It turns out that with the spinnaker up, the jib freely goes wing-and-wing as it would normally.

### Hoops Prevent Ooops!

The running rigging used to set the spinnaker on AC-32 is similar to that on full-scale boats. In addition, like on some sailing dinghies and other smaller peopleboats, a retractor line is attached to the "center" of the spinnaker that is used to collapse it, bunch it up, and lower it usually through a bow hatch into a self-bailing furling tube below deck. Larger peopleboats without a retractor line douse the spinnaker by releasing the afterguy, lowering the spinnaker halyard and reeling in on the sheet. Lowering a smallish spinnaker using a center-loaded retractor line is more efficient when the crew is shorthanded (like on an R/C model). My previous spinnaker equipped M's and Ten-Rater models did retract the spinnaker through a bow hatch and into the hull. But, unlike the Doug Lord designed boats from microSAIL!, I did not provide a belowdeck self-bailing tube for stowing the spinnaker. After experiencing in the past, two sinkings and a few near-sinkings, I decided with the new AC-32 to stow the furlled spinnaker on deck and avoid having the water-scoop of an opening at the bow. Wire "croquet hoops" in a row aside the mast serve as a stowing rack for the

retracted spinnaker. Sailing purists might be quick to point out that the hoops and stowed spinnaker on top of the deck are a windage factor. But, when you consider the overall size of the AC, consider the small size of the hoops, and consider that the wind at water surface is not all that perfect to begin with, I'll argue that the windage involved is not all that big a deal.

The deck hoops on AC-32 are made of one-eighth inch s.s. rod. Each hoop is spaced 4" apart and is progressively smaller and shorter as they proceed aft. The series of hoops start out being centered on deck and then proceed aft down the starboard side on an angle that takes the stowed spinnaker alongside the mast and main deck hatch. Discs about one-half inch thick made from birch dowel are epoxied belowdeck to serve as mounting blocks for the hoops. Plastic "noodles" made from model

airplane outer-section push-rod cut into quarter-inch long sections cover the hoops making for roller bearings. Shorter noodles like these are placed at the corners of the hoop to facilitate the right angle bend. Providing for a jib tack deck fitting is a 4" length of rod that is secured to the top-center of the forward hoop and goes aft directly above the deck centerline and connects to the top of the second hoop. Usually, an AC jib club is about an inch and a half above the deck. This hoop-mounted jib tack fitting puts the jib club at about three inches above deck. The good or the bad of jib club height could be debated, but this on-deck spinnaker stowage rack requires it.

### Spinnaker Running Rigging

In addition to the retractor there are five other lines involved as spinnaker running rigging. A halyard is



*When retracted the spinnaker is neatly furlled close to the deck by the hoops. The trolley is well aft and is keeping elastic-loaded tension on the foreguy that keeps the pole snug against the forward side of the mast.*



*As the boat is turned on to a run, the spinnaker winch is actuated. The trolley moves forward pulling up the halyard. At this point, when the elastic is running through the trolley free of stopper knot contact, tension is minimal on the foreguy, topping lift, sheet and afterguy.*



*The trolley is going forward and is in the area near the mast. The halyard has the spinnaker about half way up. The elastic passing through the trolley has made contact with the foreguy's stopper knot and is now pulling on the topping lift, sheet and afterguy.*



*The trolley is at the end of its run. The halyard has brought the spinnaker head up against the block where the jibstay meets the mast. The retractor line is slackened. The trolley is all the way forward and providing the needed tension on the topping lift, sheet and afterguy.*

needed to hoist the head of the spinnaker up the mast to the height of the jibstay fitting. A sheet is led from well aft on the leeward side of the boat, forward outside of the shrouds, and then secured to the spinnaker clew. The afterguy is a line led from well aft on the boat's weather side, outside the shrouds, forward through the spinnaker pole end fitting (a nylon servo clevis), and is then secured to what then becomes the spinnaker tack. When gybing, what was the spinnaker afterguy becomes the spinnaker sheet by removing it from the clevis, and what was the spinnaker sheet becomes the spinnaker afterguy by inserting it through the clevis instead. Two more lines are needed for holding the end of the spinnaker pole in position. One is the topping lift coming from up above and that lifts the pole up perpendicular to the mast. The other is the fore-

guy that keeps the pole from going up above perpendicular and also serves to draw the pole down holding it in place in line and front of the mast when the spinnaker is retracted. Afterguy, foreguy and topping lift together form legs of a tripod that keeps the outer end of the pole firmly placed in position. A spinnaker will not set or fly right if the pole is free to flop around.

#### **R/C Equipment**

Hoisting a spinnaker by R/C need involve only one channel and one winch. A hobby shop's radio technician service could adapt a four channel transmitter by taking either the L.H. stick's unused right-left function or the R.H. stick's unused up-down function and mount either as a separate, rotating control knob on top the transmitter case. Of course, the spring-loaded self-neutralizing effect is eliminated.

Avoid using a simple two-position on-off toggle switch such as that provided on the typical transmitter for the purpose of operating a model aircraft's retractable landing gear. When the boat is on the workbench and you are first installing the spinnaker system, or when at the pond and checking things out prior to launching the boat, you will want to do any test hoisting or retracting in slow increments. A rotating knob allows you to do this. Blasting the spinnaker up or down while using an all-the-way-up and all-the-way-down toggle switch without first being certain that all things are clear and ready is inviting a train wreck. The spinnaker winch installed in AC-32 is an RMG SailWinch model SW380. RMG's Rob Guyatt custom made this stump-puller that can reel in 40" of line in five seconds. This fast, powerful winch is a real joy. It is an ideal winch for the job. Now that the SW380 is available in this big-horsepower "long travel" custom made version, I would imagine that more R/C sailors will be inclined to experiment with spinnakers.

Over the years, I have encountered probably a half dozen other folks that have worked at installing a spinnaker system. They all have said the biggest problem encountered was the strain on the retractor when the spinnaker would bunch up at the deck hatch opening. To lessen the problem a roller of some kind is needed where the bunched up spinnaker turns the 90-degree bend from being vertical to being stowed horizontally in the hoops or tube. Actually, a roller is needed on each side of the opening as well as on the aft edge. The rollers need to be at least a half-inch in diameter so as to lessen the drag of a sharp turn. My mounted on-deck hoops are covered, top and sides, with loose-fitting small plastic "noodles" that roll nicely as the spinnaker passes through. The forwardmost hoop, where the spinnaker is gathered by the retractor and makes its turn, is actually a close-fitting group of three hoops that together in effect form a single three-sided roller having a diameter of about one-inch. There is also one other means of avoiding strain on the winch. It's a cure discovered years ago by Henry Morris -- Two words: Parasail Cloth.

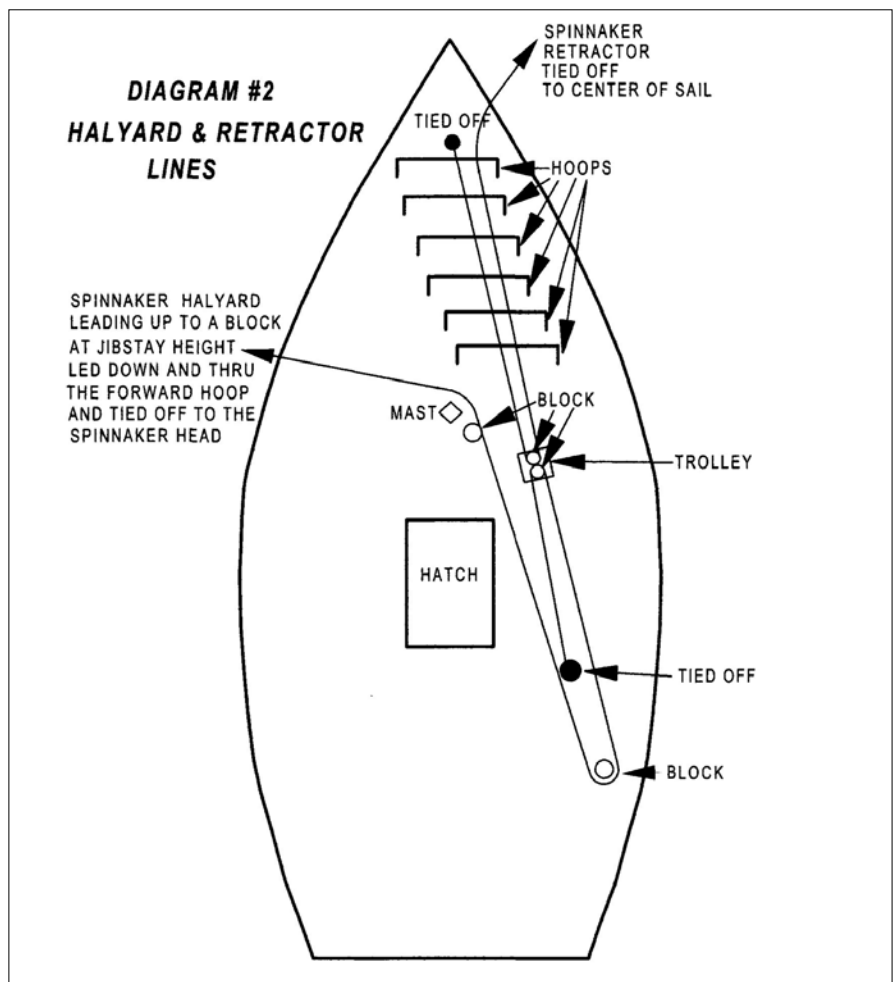
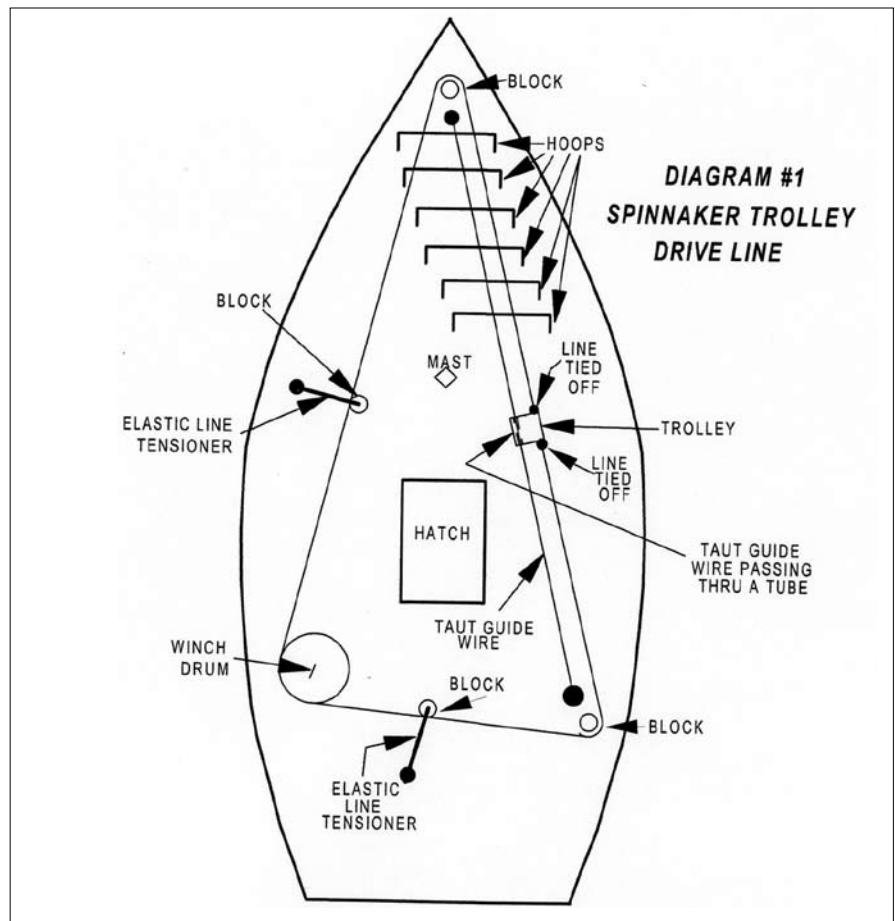
Mainsheet and jibsheet are run from a belowdeck Ozman swinging arm sail control. All running rigging for the spinnaker is mounted on deck. This drawing shows the first "layer" of lines involved. The function of this layer is to haul the spinnaker trolley fore and aft. These lines are flush with the deck and run under the hoops. The drivelines from the winch are tied off to the trolley. The guide wire keeping the trolley on track passes through a tube on top the trolley. All diagram drawings by Paul Meskill.

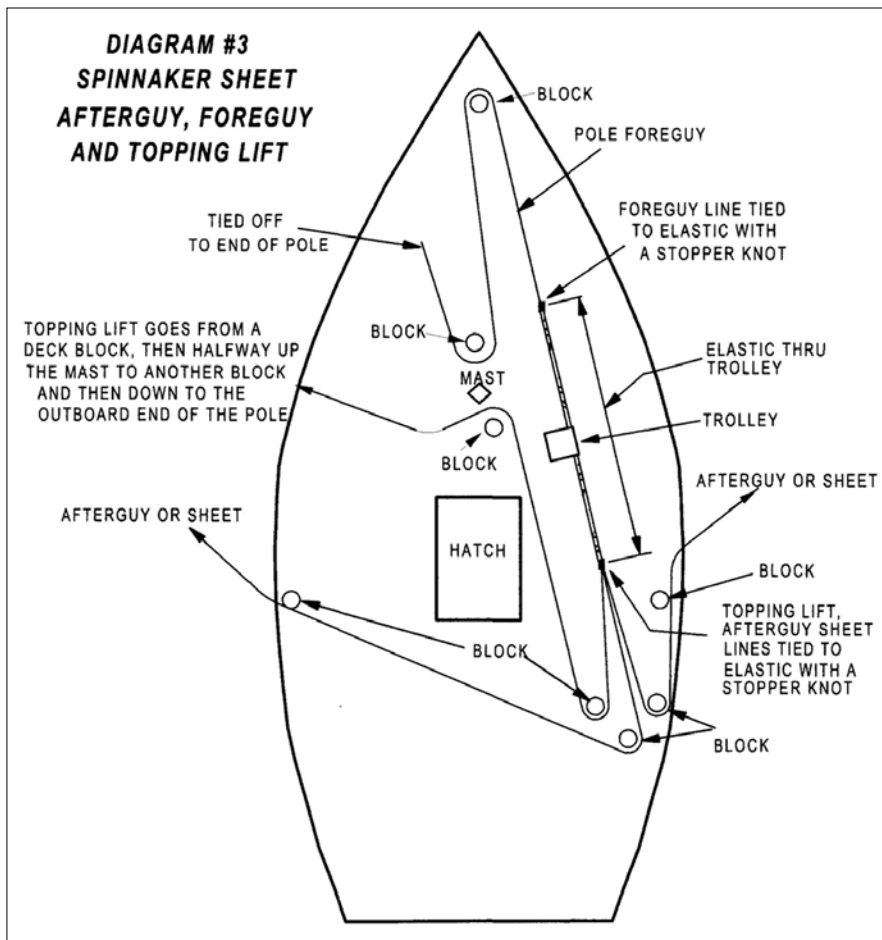
Typical peopleboat spinnaker cloth is coated with something that makes it stiff and that makes it cling to itself and to everything else when wet. Parasail cloth, on the other hand, is coated with a urethane of some kind. Parasail cloth, on the other hand, is coated with a urethane of some kind. It's soft and flexible as pink panties. And, since that urethane coating really does a job of shedding off any water, it does not cling. The one secret has one problem: Your sailmaker will not enjoy working with parasail cloth. It's so slick that double-sided seam tape refuses to stick to the stuff. Panel seams need be hand fed by eye into the sewing machine. Rod Carr, proprietor of Carr Sails, made the spinnaker for AC-32. He knows where to get parasail cloth, and he did a fine job on this spinnaker. But, I got the impression Rod is not too thrilled about working with parasail cloth. If you want to order one for yourself, be persuasive and you could probably talk him into it.

### Riding a Trolley

When the spinnaker winch on AC-32 is actuated it propels a trolley forward, or aft, on deck for about forty inches start to stop. The trolley is a PeKaBe double turning block mounted on a plastic base. There are two sleeves, each about a half-inch long, epoxied to the top of the block. A taught plastic-coated wire anchored to the deck well aft, then stretched and anchored well forward,

This, the second "layer" of lines is there to provide the double-block purchase for the halyard and the retractor. Lines to, through and from the trolley blocks run flush with the deck and under the hoops.





*This is the third “layer” of lines involved. The hoops are still there, but not shown on the drawing so as to make the labels and pointers more legible. The elastic and its lines, where they start out, are run flush with the deck and under the hoops. As the driveline shown in Diagram #1 moves the trolley forward or aft as it hoists or retracts the spinnaker as in Diagram #2, a tube on top the trolley will also make contact with the elastic’s stopper knots shown here on Diagram #3. Contact with a stopper knot generates the trim or ease needed to work the foreguy, topping lift, sheet and afterguy.*

passes through one of the sleeves. This guide wire and the plastic base keep the trolley on track without any twisting or turning as it scoots along. The spinnaker halyard passes through the traveling block’s lower sheave, and the spinnaker retractor line passes through the upper sheave. These two lines being pulled or eased by a traveling block (a moving block rather than a stationary turning block) going 40” provides a resulting two-to-one 80” of travel needed to fully hoist or retract AC-32’s spinnaker. Think of it as a block-and-tackle being used in reverse of typical order – A short heavy pull is providing a fast, long run of trim. As the trolley moves towards the bow pulling up the aft led halyard it is easing the forward led retractor line at the same rate. And, vice versa, when the

trolley runs aft it pulls on the retractor as it eases the halyard.

Passing through the other sleeve fixed to the top of the trolley is a length of dressmaker’s elastic. This one elastic cord has a big job. It operates the spinnaker sheet, the afterguy, the pole topping lift and the foreguy. The foreguy is tied with a stopper knot to the forward end of the elastic. Tied with a stopper knot to the aft end of the elastic are the three remaining spinnaker control lines: sheet, afterguy and pole topping lift.

As the trolley moves forward the elastic rides freely through the sleeve until it meets the foreguy’s stopper knot. Pull is then being applied to the sheet, afterguy and pole topping lift. Also, as the trolley moves forward the elastic releases its tension on the fore-

guy so that the topping lift can take over and hoist the pole into position.

As to be expected, when the trolley is run aft the retractor line is hauled in, as is the foreguy once it hits the stopper knot on the aft end of the elastic. At the same time; halyard, sheet, afterguy and topping lift are being eased because their stopper knot at the aft end of the elastic is being pushed along aft.

A quarter-inch diameter bead is fitted on the foreguy, between the stopper knot and it’s first turning block at the bow, to act as a stopper that limits the pole from being hoisted any higher than wanted. Stopper beads are also fitted to the spinnaker sheet and afterguy, between the gunnel mounted turning blocks and their attachment to the spinnaker, so as to set these two lines in proper trim when the spinnaker is up.

Determining the proper length of the elastic, determining the length of the various lines, and determining where the stoppers need go is something that defies easy description. The answer to the equation comes from experimentation and trying different combinations of the three.

Instead of a block and tackle device like a trolley, a winch having multiple drums of various sizes could be used to hoist, retract and trim a spinnaker. It’s just another way of doing the same thing. But, in addition to custom making winch drums in precise diameters, there are real problems in figuring out a way to avoid overrides when lines go slack and also to figure out a way to avoid a line from overlaying on itself as it is spooled on to its drum. A drum’s diameter increases dramatically when multiple wraps get bunched up all on one side. The spinnaker halyard needs to accurately draw the spinnaker head very close to the mast or the sail will swing wildly side-to-side. On the other hand, if the halyard line should overlay itself on the drum too much line will be hauled in and it will cause the winch to crash as the spinnaker head jams against the halyard mast block. Another consideration is that when the halyard and retractor are in motion, the motion of the other four spinnaker control lines needs to be coordinated accordingly. You cannot have one of the lines go-

ing taught against another at any time during the hoist or retract. It is a virtue of the elastic when riding a sleeve on a trolley that some tension will always be there to take up any slack and also be there to provide trim when appropriate.

### Running Rigging Routing

The spinnaker halyard is dead-ended aft to a cleat, led forward to a sheave on the trolley, back aft to a turning block, forward to a turning block at the base of the mast, up to another turning block just above the jibstay fitting, and then down through the first hoop where it is secured to the spinnaker head.

The retractor line is dead-ended at the bow; runs aft inside the hoops to the trolley's other sheave, led back forward inside the hoops and is then secured to a reinforcement patch in the "center" of the spinnaker. About 3" of slack is allowed in the retractor line so as to prevent a pucker in the middle of the spinnaker when the spinnaker is up, full and flying. This slack in the retractor presents no problem to the operation of the trolley, or anything else.

Tied with a stopper knot to the forward end of the trolley-riding elastic is the pole foreguy that runs inside the hoops to a turning block at the bow, then back on deck outside the hoops to a turning block at the base of the mast and is then led to and knotted to the clevis on the end of the spinnaker pole.

From the knot at the aft end of the elastic the topping lift goes to a turning block aft, then forward to the base of the mast, then up to a turning block fixed about half way up the mast, and then back down to the clevis

on the end of the spinnaker pole.

Also tied to the knot at the aft end of the elastic are the spinnaker sheet and afterguy. Both are led aft to turning blocks near where the aft end of the trolley guide wire is anchored. One of the lines is then led forward to a turning block located on the starboard gunwale about a foot aft of the mast. The other line goes to a turning block portside. These turning blocks need to be mounted where the hull is at maximum beam and forward just enough where their lines will not interfere with the main boom when the spinnaker is up and flying. The lines continue forward, outside the shrouds and are then tied off to the spinnaker. Because the spinnaker is intended for running directly downwind, both sheet and afterguy are the same line length and have the same amount of trim travel. They are also the same length because they need to be interchangeable with each other when one is switched around with the other as being the sheet or the other being the afterguy. When the spinnaker is retracted enough slack needs to be built into the afterguy so as to allow the pole, with afterguy in its clevis, to be drawn in so that the pole is stowed inline with the forward side of the mast. These three or four inches of slack in the sheet when the spinnaker is stowed results in it drooping outside the gunwale and dragging in the water. Dragging a line is contrary to big boat etiquette and supposedly detrimental to boat speed. But it's doubtful this thin drooping line will cause more than a negligible drag on an AC.

### Problem Preventers

When hoisting or lowering a spinnaker on a model boat a variety of

problems can be encountered. It's not like with a peopleboat where a crew is there to oversee that everything goes right. Inventing and installing devices to prevent problems can be as much a project as is installing the hoist-retract system itself. Below is a list of things to consider.

**Preventer #1:** To keep the pole from being lifted while caught behind a shroud, a taut line runs in front of the mast from one forwardmost sidestay across to the other forwardmost sidestay. This line is about six inches above the deck and aft of the spinnaker pole.

**Preventer #2:** To keep the pole from being lifted to leeward instead of to weather, a short length of stretched elastic cord is run from one-third down on the pole, then over and clipped to the foremost shroud on the weather side of the boat. The elastic loaded topping lift is always pulling up on the pole whereas the afterguy is slack for the first moment during the hoist. This means that you can't always rely on the slack afterguy passing through the clevis on the end of the pole to pull the pole to the weather side. As the trolley runs forward, easing the foreguy and pulling up on the topping lift, this preventer will give the pole a head start in the right direction.

**Preventer #3:** To keep a line from tangling at a deck-mounted block that leads a line upward, a short length of model airplane rubber fuel line is put around the block's shackle so as to hold the block vertical. There are halyard, topping lift, sheet and afterguy deck blocks that lead their lines in an upward direction. A rubber collar around the shackle holds the block upright and still allows the block to freely angle itself to

## Rod Carr, Sailmaker

3011-177th Ave. NE  
Redmond, WA 98052-5825

Phone: (425) 881-2846

Fax: (425) 869-7306

E-mail: [RodCarr@CarrSails.com](mailto:RodCarr@CarrSails.com)

Web Site: <http://CarrSails.com>



Quality Model Yacht Sails For ALL R/C Racing Classes, Scale and Vintage Since 1969

## DENNIS DESPROIS' R/C YACHTS

**GAMBIT 36 GAMBIT US1M  
AMERICAN FOOTY**

**SPECIALIZING IN HIGH PERFORMANCE  
SAILS FOR:**

**US1M 36/600 ODOM FAIRWIND  
US12 VICTORIA 50/800 ect.**

Custom made sails also available



Look for the WALRUS  
on the tack!

Web Site: [www.ddesprois-rc-boats.com](http://www.ddesprois-rc-boats.com)

E-Mail: [dddsc@yahoo.com](mailto:dddsc@yahoo.com)

Phone: 480 998-3754

the line's direction of travel.

**Preventer #4:** A U-shaped s.s. wire fitted over the spinnaker winch drum prevents a slackened trolley driveline from jumping off or crossing over to the other sheave. This wire needs to be carefully fitted so that it just barely makes contact with the sides of the drum, yet does not allow enough of a gap for a line to slip past it.

**Preventer #5:** Blocks shackled to elastic cord ride each of the trolley drivelines so as to help take up any slack that might develop. The drivelines are subject to a significant stretching load when the spinnaker is first hoisted out of the hoops and then again as the spinnaker is being retracted and it bunches up at the first hoop. Stretch and resulting slack in the drivelines is inevitable. An elastic-loaded block pulling the driveline to the side of its direction of travel will provide the slight tension needed for spooling the line properly on to the drum.

**Preventer #6:** To prevent the spinnaker from going over the bow and being caught while it is being retracted, a very thin elastic cord is led from the top of the mast, down through a screweye in the tip of the bow, and then tied off to the trolley. When the spinnaker is up, and the trolley is forward, this elastic becomes really limp and does not interfere with the shape of the spinnaker. When the trolley runs aft it draws some tension into this elastic "headstay" and eliminates the possibility of any part of the collapsing spinnaker from hooking over the bow.

**Preventer #7:** To prevent the spinnaker from snagging under the offset jib club a short length of heavier elastic cord is led from the very tip of the club, under the tallest of the forward hoops, and then a loop at the end of this elastic is inserted into the jib tack snap shackle fitting. With the jib forestay also attached to the very tip of the jib club, as



is this elastic cord, nothing protrudes from the club that might catch the spinnaker as it is hoisted. In effect, a "smooth" running surface is presented from the top of the first hoop all the way up along the jib forestay.

**Preventer #8:** To prevent the spinnaker pole from getting caught in the jib club topping lift when the spinnaker is going up or down, you simply go without having a jib club topping lift. If someone were to invent a preventer that allows using a jib topping lift, I sure would like to learn about it. In the meantime, adjustable backstay tension is used to control the shape of the jib's leach.

**Preventer #9:** To prevent the spinnaker pole from getting caught between the loose-footed jib and the jib club

when retracting the spinnaker, the boat needs to be steered up on a reach so as to get the jib to leeward and out of the way as soon as the retract function is actuated. You can avoid the problem entirely by locating the pole gooseneck up high enough on the mast so the clevis end of the pole is always higher than then the aft end of the jib club. There is no problem when hoisting the spinnaker and the jib is to weather wing-and wing. The pole as it rises will force the jib over to leeward or out of the way. Once the spinnaker is hoisted and the pole is up and drawn aft into position, the jib is free to go wing-and-wing as it might normally.

**Preventer #10:** To prevent spinnaker running rigging from snagging on main boom or jib club hardware, keep

**MODEL YACHT FITTINGS**



**Roger Cousineau**  
44 Moses Little Drive  
Windham ME 04062  
(207) 892-4816

[www.modelyacht fittings.com](http://www.modelyacht fittings.com)  
Brass fittings for scale and pond boats

**RMG SAILWINCH**

**SmartWinch** 

*High speed, high torque intelligent winches*  
[www.users.bigpond.com/rmgsw](http://www.users.bigpond.com/rmgsw)

66 Radford Rd  
Angaston 5353  
SOUTH AUSTRALIA

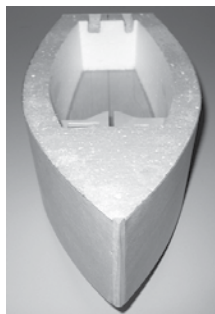
[rmgsw@bigpond.com](mailto:rmgsw@bigpond.com)  
ph: 61 8 8564 2444  
fax: 61 8 8564 3474



# Scalesailing

1535 Nth. 36th Street  
Sheboygan, WI. 52081  
tel: (920) 208-6863  
scalesailing@sbcglobal.net  
www.scalesailing.com

Footy Kits, Sails, Keel Bulbs  
Foam Core Hulls, Accessories



*Kittiwake* \$69.95 + S&H  
an AMYA class Footy.  
Easy to build kit based on a  
ScaleSailing Foam Core Hull

Kit includes; foam core hull,  
ply core skins and other wood  
parts all laser cut, cast lead  
bulb, finished sails, aluminum  
mast, all fittings, rigging,  
photo CD & instructions.



the bottom and side surfaces of these spars smooth and free of obstructions. Hardware fitted to the top surface of either spar is not a problem. A loop of line hanging an inch down from a hole in the boom or club will provide a snag-proof attachment point for a sheet and its fishing tackle clip. Adjustable outhauls need be nothing more than a length of line led bowsie style through three holes in the boom. It is important that the string leaving the grommet at the sail's clew be led directly to the very aft tip of the spar. This will present a smooth, snag free surface to any line passing by it.

Preventer #11: To prevent the pole as it is being raised from getting caught behind the halyard or topping lift, lead both lines as they come off the deck from behind the mast and behind the spreaders when on their way up to their mast mounted turning blocks. Once through the turning blocks, the halyard and topping lift lines are led down forward the mast.

Preventer #12: Only a word of caution: If it's blowing stink and you are in traffic, don't hoist the spinnaker. Or, if the time comes and you can't resist the temptation, please arrange to have a photographer with you and be sure to send the photos to *Model Yachting*.

#### Rigging-Up at the Pond

Rigging up at the pond does not take long. Before sticking the mast in its socket, you need make sure that the sheet and guy are outside the shroud turnbuckles. Once the standard jib, backstay shrouds and sheets are secured it's then time to deal with the spinnaker. Unless you have a ladder with you, or unless you can reach about ten feet up from the ground, the boat is lifted from the cradle and laid on its side. The elastic preventer running from the screweye in the bow is drawn up and S-hooked to the top of the mast (10 seconds). The elastic Preventer attached to the front tip of the jib club is passed under the first hoop and then its looped end is slipped into the jib club tack swivel snap (20 seconds). The spinnaker halyard has a loop tied at its end.

It is led up from the deck backside the mast, backside the spreaders, fed through the block above the jibstay, down forward to and under the first hoop where it is snapped to the head of the spinnaker (45 seconds). The spinnaker topping lift has a loop on its end. It is brought up from the deck backside the mast and spreaders, passed through a block halfway up on the mast and then the loop goes down to deck level where it is inserted into the clevis on the end of the spinnaker pole (30 seconds). The foreguy is now inserted into the clevis (15 seconds). All that remains is to decide which is to be the sheet and which is to be the guy and insert that which is to be the guy into the clevis (15 seconds). Clip the elastic preventer to the shroud that will get the pole started up on the correct tack (10 seconds). Pick the boat up, stuff it back in the cradle, point it downwind, turn on the radio, and in slow increments cycle the spinnaker up and down a couple times so as to check things out (60 seconds). Note: In drydock or in use, the pole is always attached to the mast with a gooseneck just as is the main boom.

## **MIDWEST** *Midwest Model Yachting, LLC* *R/C Model Sailboat Fittings and Supplies*

### **Masts, Booms, Fittings, and Supplies In Stock**

#### **SAILSetc - KDH - Cap Maquettes**

Full catalog and online ordering at  
[www.midwestmodelyachting.com](http://www.midwestmodelyachting.com)

50 Page Catalog \$6.00

Also offering Blackmagick sails, RMG winches, ballasts, sailmaking supplies, and more

e-mail: [rcsailing@midwestmodelyachting.com](mailto:rcsailing@midwestmodelyachting.com)

P.O. Box 605  
Plainfield, IN 46168-9998

Phone/Fax: (317) 203-3121

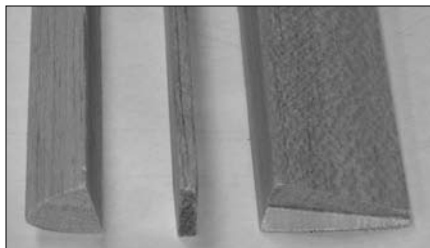
**Visa, Mastercard & Discover**

# Rotating Wing Mast on a 10R

*Editors note: The pictures were intended to be at the end of this article, but for space reasons, we needed to place them within the text of the article.*

by Mark Gee

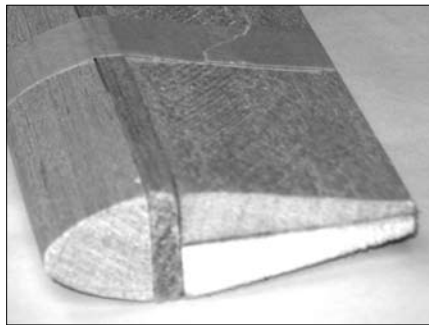
While the concept of using a rotating airfoil shaped mast on a sailboat is not a new idea, there are surprisingly few classes of boats that either allow or choose to use them. Most commonly seen on high performance catamarans, the increased performance when using an “active” rig of this type is undeniable. I consider a rotating mast “active” because of its automatic and continuous movement to maintain an ideal angle with the desired sail position. The concept is simple: by allowing your airfoil shaped mast to rotate to a balanced position into the apparent wind, the entire rig takes on a higher level of efficiency and power. Working in the same way as a leading edge slat on an aircraft wing, a rotating mast promotes smoother airflow transition between the mast and sail,



*The three stock balsa sections that make up the airfoil are shown just prior to assembly: 3/4" leading edge, 1/4 x 3/4" center spar, and two 3/8" trailing edge sections (glued back to back). All photo's by Whitney Gee, January 2005*

which ultimately results in several areas of increased performance.

One of the best examples of wing mast technology in use today is found in the “C” class catamaran fleet, where 40-foot tall, camber adjustable, rigid airfoils are used in lieu of traditional soft sails. Although the “leading edge” technology in this class has nearly caused it to be engineered out of practicality, the huge amount of power generated by the rigs on these



*All sections assembled and glued with epoxy. Stagger seams between pieces as needed to avoid multiple joints in the same area. Mast can be assembled to length in one step or in sections. After curing, only a light sanding is required to smooth the edge joints. If a different chord shape is desired, the trailing edge may be trimmed and then re-shaped. Reinforcement plugs where fittings will be attached have been glued, faired, and sanded.*

boats is amazing. For example, a well-designed racing boat with a traditional mast and soft sails produces a lift coefficient of around 1; “C” cats using rigid wing masts have an optimum lift coefficient of 2.4. Get your attention? It does for me, especially when you realize that the rig on any high performance sailboat has the same function as that of an aircraft wing – generating lift. To explain the concept even more simply: there are reasons why modern aircraft use rigid wings rather than fabric covered airfoils – mainly efficiency and control. So how can all this technology be applied to model yachts? The answer is found by combining the efficiency and power benefits of a rigid wing mast with the simplicity of a traditional soft sail rig. More specifically: pairing a rotating airfoil shaped mast in combination with a soft sail.

In the model yacht classes, rotating masts are nothing new to the multihull group, where in the upper wind range the mast alone can generate enough power to easily drive the boat. In monohulls, anyone familiar with the Skalpel is also likely to admit the efficiency of its rig is a key factor to the success of that design. As history once again repeats itself, some might

remember that rotating wing masts were used very successfully on several European 10R's in the mid 1960's. The wing mast rigs used at that time were in fact so superior to the traditional rigs, that the class rules had to be changed just to prevent the rest of the fleet from becoming obsolete. Today, the Marblehead class shows a similar trend with the success of the Skalpel, so the performance gain with this type of rig is hardly disputable. Although their setup and engineering is slightly more complex than traditional rigs, the performance advantage makes it



*The mast at this point has been sealed with a coat of West Epoxy, sanded, and primed. Note location of downhaul turning eye and cleat. Bearing supported pivot pin at base also visible. Hardwood plugs are located under the pivot pin, and cleat screw locations.*

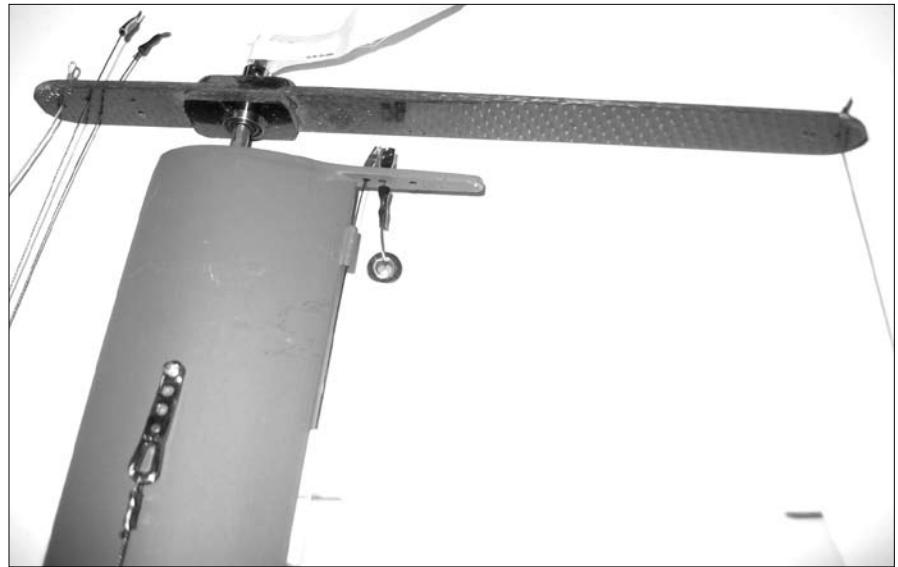


*A standard setup of single diamonds is used. Even though it is made of balsa, the mast is surprisingly rigid on its own, requiring only minimal supporting rigging.*

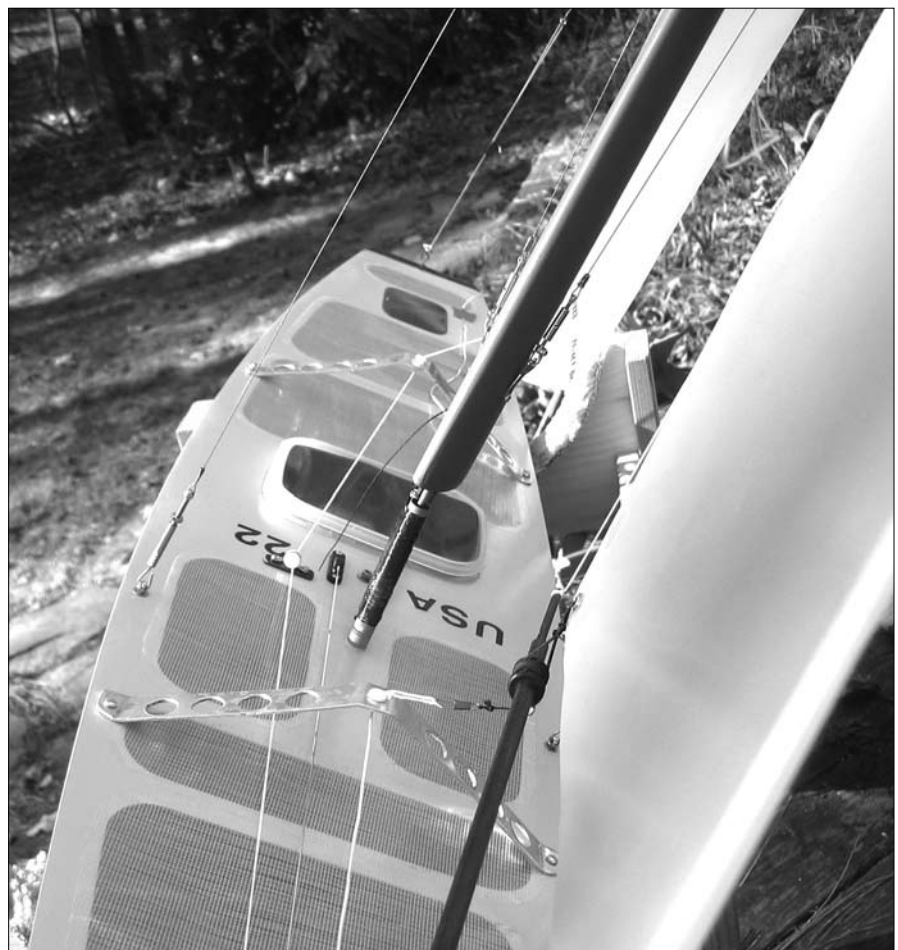
justified.

Fellow 10R skipper, Whitney Gee, has developed a rotating mast for his 10R, which clearly demonstrates some attractive performance characteristics in side-by-side comparisons to traditionally rigged boats. The mast and rig he has developed caters very well to the 10R class, which has no dimension limits on mast chord or thickness, allowing an airfoil size and shape ideal for maximizing efficiency. His rig is very simple and affordable to make and could be applied to nearly any sailboat on the water today – class rules permitting. It is likely though that only the developmental classes will ever be able to experiment with this type of rig, but I see Roating Wing Masts as one area of yacht design that has hardly evolved since Bermuda rigs were introduced in the 1920's.

Building a Balsa wing mast is actually quite easy, and only slight modifications to the traditional standing rigging setup are necessary to allow the mast to rotate. The mast itself is made up of only 4 basic balsa parts, all of which are pre formed: a



*The head is nearly the same as the base. Main halyard, upper pivot pin, and main-sail crane are shown. The small crane provides support to the head of the main sail as the mast rotates. The carbon fiber mast crane is double bearing supported, which allows traditional backstay and headstay tension, while still allowing smooth mast rotation.*



*Mast has been stepped on boat. Traditional shrouds are used, but all standing rigging runs to the carbon fiber mast crane. Only diamonds are needed to control mast bend since rotating masts incur different loads than typical rigs. Using an offset (detached) gooseneck allows free rotation of the mast during all points of sail. The mast has already rotated some due to the heel of the boat.*

rounded leading edge section, a vertical spar section, and two sections of trailing edge stock. The balsa pieces used in the photos that follow are common, pre-formed stock used to construct model aircraft wings. Sizes can be varied depending on your preferences for mast chord and thickness. When choosing your balsa stock, you will see how easily all the pieces fit together, and since there is virtually no shaping required before assembly it is easy to create a very straight mast. Once the mast section is assembled,

the only remaining construction needed is to install hardwood reinforcements in the areas where fittings will attach. This is easily done by gluing in “plugs” from a hardwood dowel at the head, base, and center mast sections. The rest of the engineering lies in laying out the standing rigging and creating a reliable method to ensure the mast will actually rotate. The use of a shaft and bearings is ideal, but the use of a pin/step or a ball/socket combination would provide good results as well. The photo’s that follow will

show how these parts are assembled, and the ideas that we have used.

To read more about wing masts and the “C” class of catamarans, reference the January 2005 issue of Sail magazine. Another good account of high performance multihull sailing and technology is in the book *The Race* by Tim Zimmerman, which covers the 2001 nonstop, round the world, sailboat race intending to beat the Jules Verne goal of around the world in 80 days or less – which it did, in 62 days.



*Close up of mast step and offset gooseneck.*

# A Ball Bearing Gooseneck for the Wing Mast

by Mark Gee

Sailing predominantly in light air, many of the skippers in our club realize the value of having a smooth swinging and reliable gooseneck on their mast. While many of the commercially available products work well and are of very high quality, the design for a simple and very affordable homemade ball bearing gooseneck can be seen below. Fellow 10R skipper, Whitney Gee of Atlanta, GA developed this gooseneck design to work in conjunction with his rotating wing mast, it could be applied to virtually any class allowing gooseneck modifications. We have found that this gooseneck works very well in all wind conditions, but demonstrates excellent performance in light air where the boom will swing freely in even the lightest hint of a breeze. The parts list for the gooseneck seen in the photos is listed below. We have found that a quality hobby shop that stocks a good section of R/C car parts should carry the appropriate flanged bearings, wheel collars, tubing and rod. With the exception of boom stock material and a compression



*This photo shows the basic assembled gooseneck, ready to be glued to a mast or deck post (if using an offset gooseneck). Basic Tangs can be used as simple attach points for the boom and vang, although a Sails Etc. compression strut is used here.*

sion strut, total cost for the gooseneck itself is usually less than \$15.

Parts list:

2- flanged ball bearings—Duratrax

part #DTXC1403

1- 3" section of 5/16" brass/aluminum tube (size this to fit the bearings)

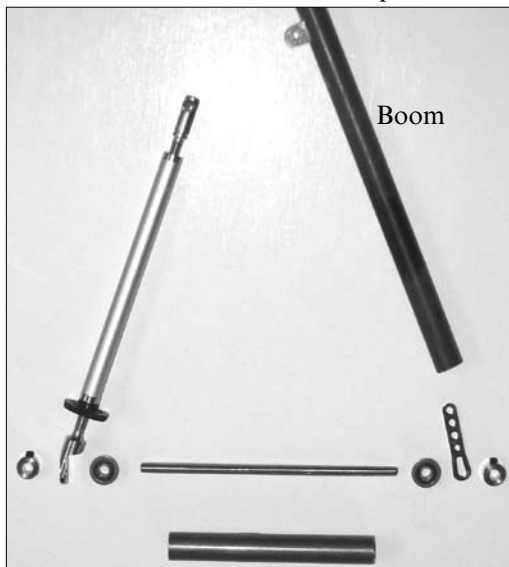
1- 4" section of 1/8" stainless steel/aluminum rod

2- tangs—Pekabe part # 406

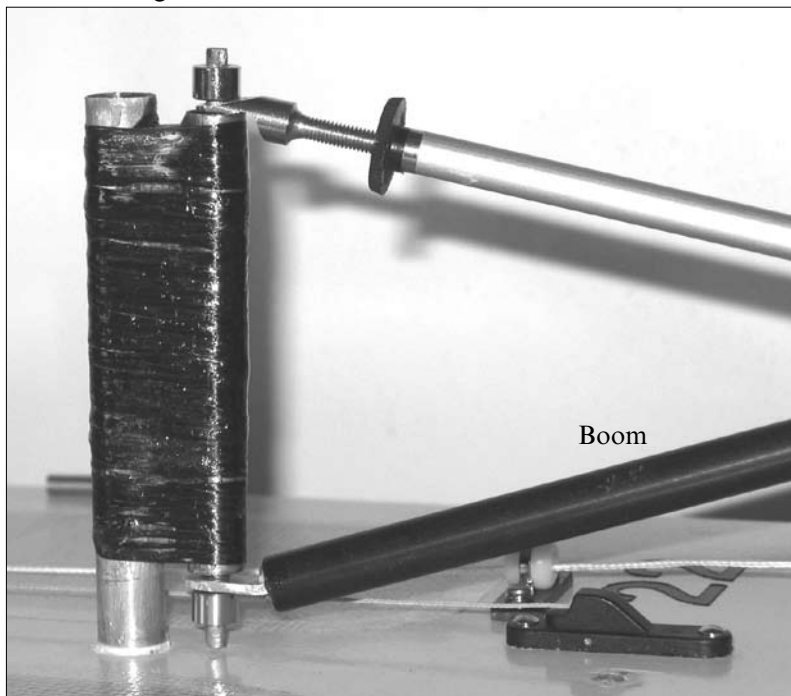
2- 1/8" wheel collars—Dubro #139

1- Compression Strut—Sails Etc. part #26c-e

The basic principle in this project is to create an axle and bearing unit. Simply insert the flanged bearings into each end of the brass tube. The flanged ends keep the bearing from sliding completely into the tube. The SS or aluminum rod slides through the inner hole of both bearings and extends out each end. A tang or compression strut fitting slips over the exposed rod ends and is held in place by a wheel collar at each end. Gently snug up all the parts on the SS rod until no up/down slop remains, and tighten down the wheel collars. If needed, a small bushing may be placed between the tangs and the BB hub to prevent rubbing on the outer edge of the bearing. Any remaining exposed SS rod may be trimmed off flush with the wheel collars.



*The photo above shows an expanded and unassembled view of all the parts cut to size and ready for assembly. Parts shown from left to right: Wheel collar, compression strut and end fitting, flanged bearing, SS rod, brass tube, flanged bearing, tang and boom, and wheel collar. Adjust sizes accordingly depending on what parts are available in your area. All photos by Mark Gee.*



*Above, the gooseneck has been attached to its post and the boom stock and compression strut fittings have been connected. Adapt your particular boom stock and vang assembly as needed to attach to the tangs or SS rod. Note the carbon fiber wrap used to bond the brass tube to the deck post.*

# Fittings

## Where'd ya get that thing, or what'z that?

by Paul Proefrock

In late 2000, we reported the status of various fitting suppliers (*Model Yachting*, Number 121). It is interesting, in four years, how much the industry has changed but how much it is still the same. Our list of fitting suppliers is limited and often, those listed don't exist or can't be contacted. To help in the search for reliable suppliers, we used ad's in *Model Yachting*, the AMYA suppliers list, and an internet search. Depending on your needs, fittings can be readily available. Like most hobbies, the more sophisticated you become, the more difficult the exact item is to find. Fittings seem to fall into three different classes: a replacement part, a standard item and a specialized piece.

If you are a member of a well organized, one design class, it may be a simple replacement part. The CR914 class has very strict one-design rules but allows modification of some fittings. The next level would be standardized parts, used to build various boat rigs. The EC12 class is probably the most documented class in history, in both plans and sources of material. Here, the search changes from which fitting to a very specific type with certain modifications to give you that little edge on your competition. But then there are the developmental classes. "M", US1M, 36/600 are cutting edge machines and the fittings become very elaborate. AC class gets into control features no other class uses and that presents different requirements. Specialized fittings often become a conglomeration of modified and self made parts.

The biggest boon to the modeler undoubtedly is the internet. In the past, sources were limited to what was available at the local hobby shop or hardware store. If you were fortunate enough to have personal contacts within the hobby, you learned of new fitting ideas and where they could be obtained. An example is the Radial Jib Fitting. You won't find one in a hobby shop. Unless you have been exposed

to it by your fellow sailors, you won't know about it. But a quick search of the internet reveals many pages devoted to it. Look at: [www.canterbury-j-class.org.nz/](http://www.canterbury-j-class.org.nz/) if you don't know about it.

But many say, "I refuse to buy one of those &8%\$ things - no computer is going to run my life," or "I'm too old to learn one of those things." Whether we like it or not, the internet is an integral part of our life. It does make things easier. In the matter of a few short hours, I was able to accumulate catalogs from 20 different suppliers. The table attached gives URL's (internet addresses) for each one.

As the research developed, we met a number of new friends - there are some new, very active, very prominent, very good suppliers to our hobby. We are very fortunate in this. But there are still a few wanna-be's that profess to have a product yet four years later, don't have a catalog, don't have a price sheet and don't answer email. Yet they continue to promote that they are supplier to the hobby. The legal profession has a term, "Caveat Emptor" - buyer beware. Talk to your buddies at the pond. Read reviews. Try email. Pick up the phone. Build your own confidence of who you are trying to purchase from. If it takes four weeks to contact a supplier to discuss the price and availability of the latest "go-fast" gooseneck, you probably should be suspect if he says he can ship it out the next day. At the same time, the guy who advertises regularly in *Model Yachting*, awards gift certificates to your class National Regatta, will ship a catalog and lists his price and inventory levels on the internet - you see the difference. *Note: AMYA does not endorse any supplier or sell fittings. The only policing we can offer is if a particular supplier is a constant problem or not in business any longer, they are removed from the online suppliers list.*

Don't overlook the local hobby shop. They may not stock the airfoil shape used to make a mast on our boat, but they do stock the ball links, quick links, stranded cable, hardware and a

hundred other items that we use. You just need to become familiar with the item and the shop owner. You won't find these in the boat section. As a matter of fact, if your hobby shop even has a boat section, you are fortunate. Our hobby draws from all the other areas: Ball links and Quick Links from the R/C Planes and Cars; Stranded cable from the control-line airplanes; 1-80 nuts and bolts from the model trains. Take an afternoon and browse your local hobby shop. Get an idea of what is available to you.

Also understand, there generally is no one perfect way of doing something. At a site I maintain for the EC12 class, I have pictures of goosenecks: there are 23 different ways (pictures) to do the same thing, a gooseneck fitting. The beauty and fun of the hobby is perfecting your design. The best way of doing something is the way you choose and have confidence in. As your confidence and design develops, you will either modify it, make it better or understand the concept is wrought with problems and move on to another design. Perfect examples of this are the design pages offered by Lester Gilbert (<http://www.onemetre.net/>) or John Rowley (<http://askducksoup.sueand-johnr.com/>). These guys not only use fittings, they get very specialized. Their sites portray the trials and tribulations they've gone thru.

So where do all these pieces come from? The attached table provides a list of resources and a few popular companies now out of business. Scattered throughout this issue are pictures of various fittings. There may be other suppliers, and we would welcome your input and reference to them. We did not list any particular boat supplier as many of them also make fittings specific to their kit. We do need to make mention of one special source of supply.

In the past few years, our lives have become global. A supplier who has been around for years is Sails, Etc. located in England. In past years, many sailors avoided dealing overseas

due to shipping and money exchange problems. This has been alleviated to some degree by credit cards and the internet. Most recently, the products of Sails, Etc are being stocked and distributed in the United States by Great Basin Model Yachts (GBMY). Other distributors may also have some of their fittings, but my experience is that GBMY has most and they do maintain an inventory. You can view the items on the internet and if you desire a catalog, it is available from both GBMY or directly from Sails, Etc. They provide many fittings to the highly competitive

IOM class and are known worldwide.

So where do you learn about all the different fittings and where they are used? One of the best ways is to attend Regional and National Championship Regattas. You'll be surprised what the guys in the next state over are using on their boats. Don't be afraid to ask questions or look at the other boats. Most sailors are quick to share how they did something.

Got an idea or source you can share? Let us know. Post your comments on any of the bulletin boards that members regularly frequent. Or

if you are one of those who refuses to use a computer, drop me a post card, I'll see that the model sailing world is made aware of it.

And to those of you who regularly surf the internet, or those who just bought a computer, these sites are pretty comprehensive in their discussion of fittings and sources:

- <http://askducksoup.sueandjohnr.com/>
- <http://www.ec12.org/>
- <http://www.proefrock.net/EC12Web>
- <http://www.onemetre.net/Technicl/Technicl.htm>
- <http://www.ec12.info>

Source/Company:	Contact Person: Postal Address:	Internet Address:	Catalog?
A.J. Fisher Company	no longer in business No address		
Bills Boatyard' Company	no longer producing parts for public No address		
Cap Maquettes	Joe Jordan Cherubini MBU, PO Box 535 Lumberton, NJ 08048 Phonelfax: 609 518 9673	<a href="http://www.cap-america.com/">http://www.cap-america.com/</a>	N
Du-Bro Products	<i>Du-Bro Products, Inc., 480 Bonner Rd., P.O. Box 815, Wauconda, IL 60084, Ph 800-848-9411, Fax 847-526-1604</i>	<a href="http://www.dubro.com/DU-BRO/index.htm">http://www.dubro.com/DU-BRO/index.htm</a>	Y
GRP Model Yachts	Adrian Olson GRP Model Yachts, 22c Roache Road, Freedom, CA 95019, Ph 831-724-7000, Fax 831-722-7108	<a href="http://modelyachting.com/">http://modelyachting.com/</a>	N
Midwest Model Yachting, LLC.	Brian Brozek Midwest Model Yachting, LLC., P. O. Box 605, Plainfield, IN 46168-9998, Ph/Fax 317-203-3121	<a href="http://midwestmodelyachting.com/">http://midwestmodelyachting.com/</a>	Y
Reichard Kahle, Jr	Reichard Kahle, Jr Reichard Kahle, 1417 Arrow Wind Ter, Charleston, SC 29414, Ph 843-478-3368	kahle67@comcast.net	N
Loyalhanna Dockyard	Don Spielberger Loyalhanna Dockyard, 7527 Gilbert Road, Bergen, N. Y. 14416, Ph 585-494-0027	<a href="http://www.loyalhannadockyard.com">www.loyalhannadockyard.com</a>	On-Line
Ludwig RC Yachts	Larry Ludwig Ludwig RC Yachts, 429 E. Wright Blvd., Universal City, TX 78148, Ph 210-659-0525	<a href="http://www.ludwigrcyachts.com/">http://www.ludwigrcyachts.com/</a>	N
Mariner Sails	Aris Tsamis Mariner Sails, 10903 Indian Trail, Suite 100, Dallas, TX 75229, Ph 972-241-1498	<a href="http://www.mariner-sails.com/RCYachts.htm">http://www.mariner-sails.com/RCYachts.htm</a>	N
Maritime Products	A J Moritz No Address available	maritimer@sbcglobal.net	N
Micro Fasteners	<i>Microfasteners, 110 Hillcrest Road, Flemington, NJ 08822, Ph 800-892-6917</i>	<a href="http://www.microfasteners.com/">http://www.microfasteners.com/</a>	Y
Model Yacht Fittings	Roger Cousineau Roger Cousineau, 44 Moses Little Drive, Windham, ME 04062, Ph 207-892-4816	<a href="http://www.modelyachtfittings.com/">http://www.modelyachtfittings.com/</a>	On-line
Pop-Up Mfg	Company no longer in business No address	Inventory now in possession of Loyalhanna Dockyard	
Proctor Enterprises	Gary & Joe Proctor Proctor Enterprises, 25450 N.E. Eilers Rd, Aurora, OR 97002, Ph 503-678-1300	<a href="http://www.proctor-enterprises.com/">http://www.proctor-enterprises.com/</a>	Y
Race Peripherals	Unable to establish contact No address available		
Radio Control Model Yachts	Herb Hoser No address	Company no longer in business	
SAILSetc	Graham Bantock SAILSetc, 141 High Street, Kelvedon, Essex, England CO5 9AA	<a href="http://www.sailsetc.com/">http://www.sailsetc.com/</a>	Y
Warehouse Hobbies	Purchased inventory of Pop-Up Mfg. Resold to Loyalhanna Dockyard No address		
Worth Marine	Greg Worth Worth Marine, 6 Barnard, Marblehead, MA 01945, Ph 781-639-1835	<a href="http://www.worthmarine.com/">http://www.worthmarine.com/</a>	On-Line
Mike Zellanack	Mike Zellanack Mike Zellanack, 4784-49th Ave. N, St. Petersburg, FL 33714, Ph 727-526-4212	<a href="http://www.ec12.com/supplier_pgs/Zellanack/Catalog.htm">http://www.ec12.com/supplier_pgs/Zellanack/Catalog.htm</a>	

# Gooseneck and Vang Construction

by Dennis Duprois

In the past when I've written a how-to or building piece, it's always been a straightforward exercise going from point A to point B. When I was asked to do an article on gooseneck construction, naturally I assumed that it would be the same. After compiling a half dozen pages of notes, I realized that explaining the function and mechanics of a gooseneck and vang was like explaining the game of baseball; very simple in concept but highly complex in the details.

Because there are so many ways of making a gooseneck and vang, many good, some barely OK and a few being nothing more than a way to attach the boom to the mast, I concluded that the best way to approach the subject is to define what a gooseneck is expected to do and how to best get to that point.

The hinge of the gooseneck has to allow for the boom to swing freely, especially in light air and remain consistent through the course of the swing. It needs to be of sufficient strength for the class of boat and be aligned perfectly with the mast. Then the geometry has to be such that it works in conjunction

*Photo #1*

*Two parts are rough cut from 3/16 inch Delron sheet and scribed using two aluminum templates. All photo's by Dennis Desprois.*

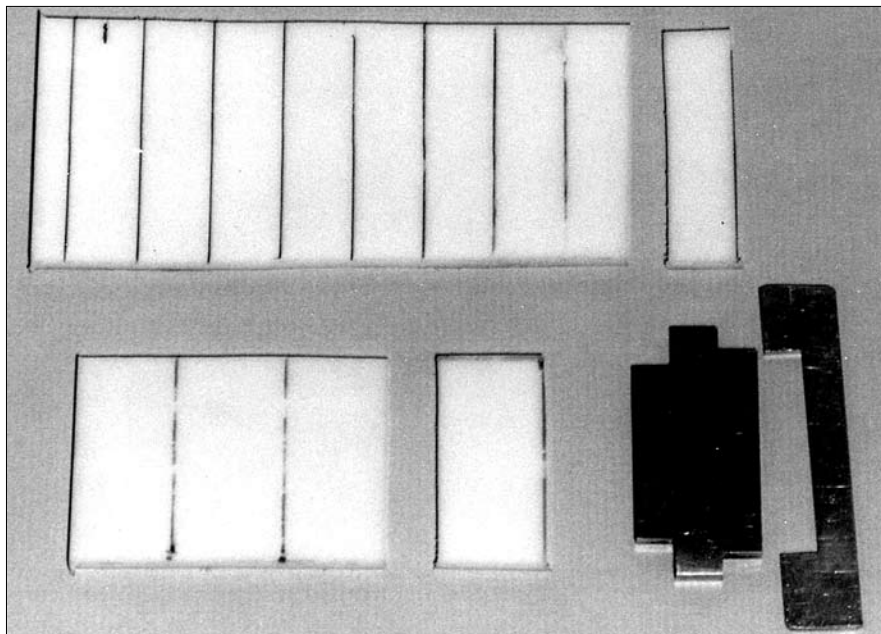
with a vang, which I feel is the key to a perfect gooseneck assembly.

The importance of the vang can't be stressed enough if you want precise trimming control of the main. With the vang controlling the leach tension on the main, it is essentially the tuning cornerstone for the entire rig. Because you want to be able to make any trim easy, a right hand and left hand turnbuckle is an absolute must. All of the kit boats have adequate goosenecks however, to a one, their vangs are sorely lacking in one aspect or another and none of them are adjustable without disassembling one part, a def-

inite impediment to making a slight trim as conditions warrant.

Because the classes I sail have a very high aspect mains that put heavy loading on the end of the boom. I like a compression vang that is completely ridged between the mast and the boom because the boom is supported independently of the sail. With a supported boom, trimming the main is more precise and there is much freer movement in light air than there is with a vang using wire or line because the sail is supporting the end of the boom.

The gooseneck and vang shown being constructed fills all of my crite-



## LEADING EDGE HOBBIES

We are a full line hobby store with a great selection of R/C sail and powerboats.  
If you don't live in the Kingston area we are happy to send your order to you.

**Pe-Ka-Be  
Victor Models  
Sails Etc.  
Thunder Tiger  
Graupner  
Robbe  
Pro-Boats  
Great Planes  
Kyosho**

Located In Beautiful Kingston, Ontario, Canada



**Futaba  
Hi-Tec  
Airtronics  
Proctor  
Dumas  
RMG  
Octura  
Aquacraft  
And Much More!**

**699 Gardiners Rd. (Gardiners Rd. & Progress Ave.)**

**Tel: 613-389-4878 Toll Free: 866-389-4878**

**www.leadingedgehobbies.com**



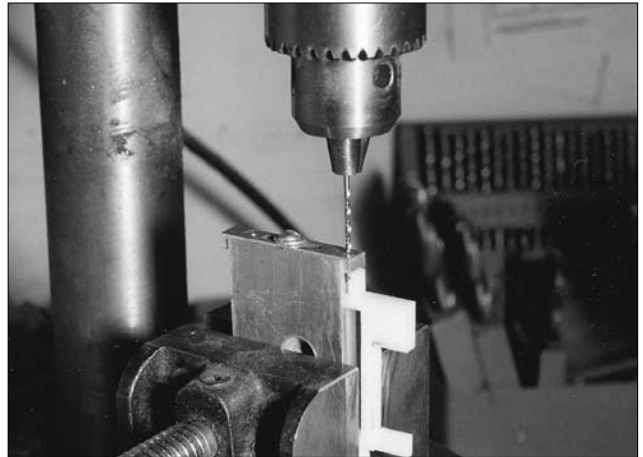
ria, lightweight, strong, ridged and easy to adjust.

This series of photos shows the sequence of constructions for a Goose-

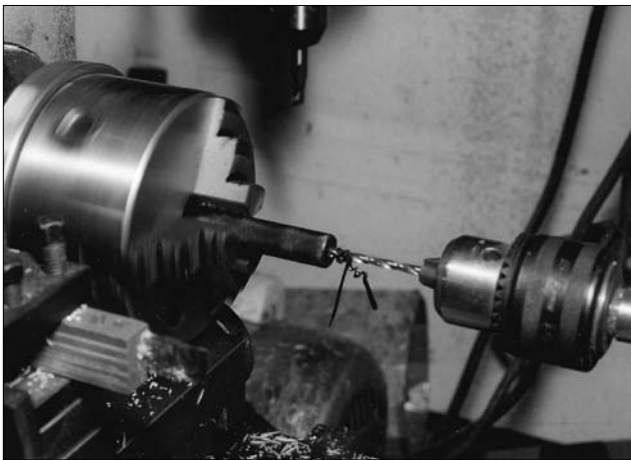
neck and Vang assembly.



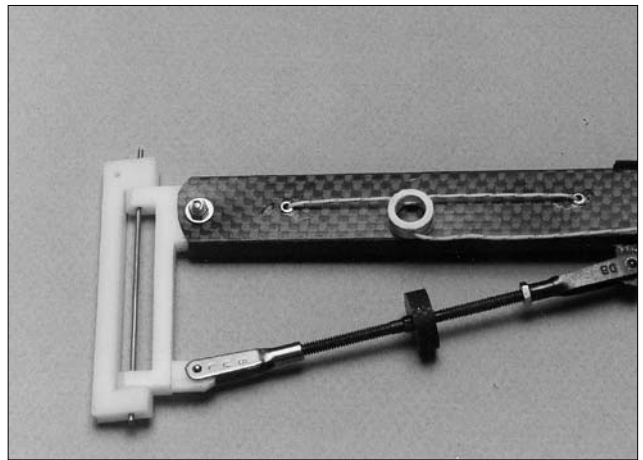
*Photo #2  
To reduce the set up time, I mill three pieces at once. This is the outside part that connects the vang and boom.*



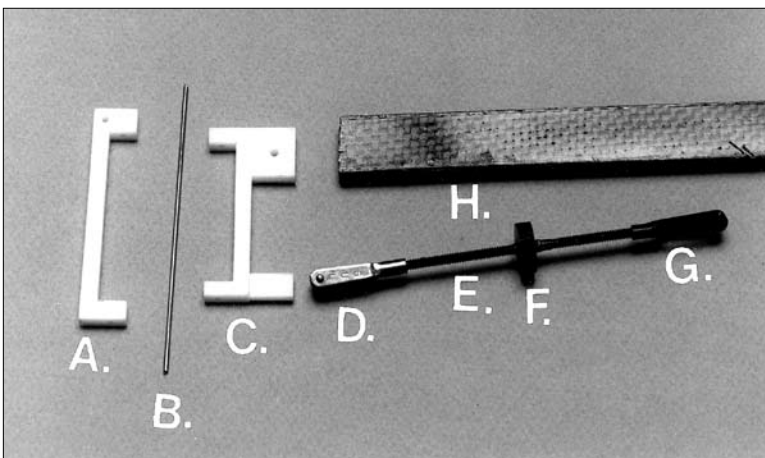
*Photo #3  
When parts are milled, they are put together and by using a jig, a perfectly aligned hole is drilled through all parts for the hinge pin.*



*Photo #4  
A half-inch Delron rod is knarled and drilled then trimmed to go over turnbuckle for a grip.*

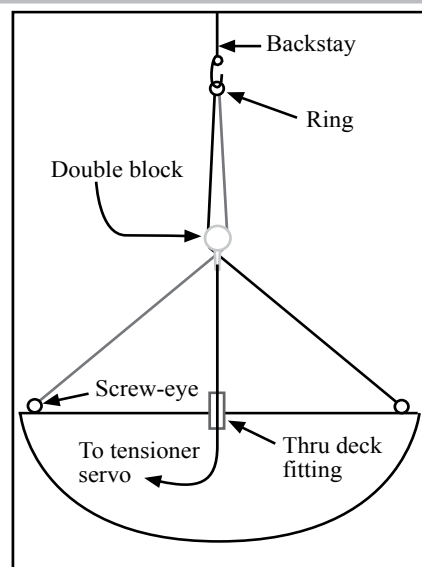
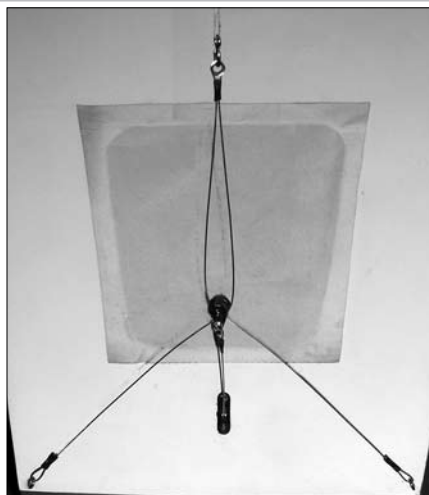
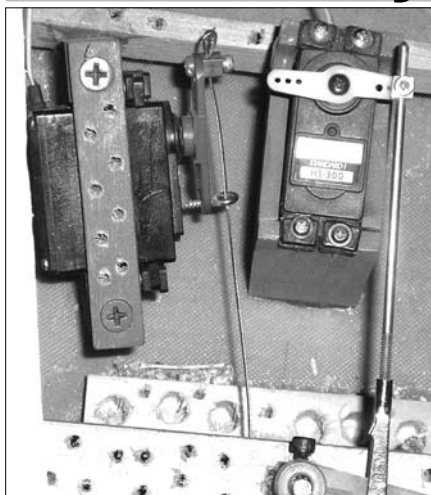


*Photo #5  
Gooseneck and vang assembled and fitted to molded carbon fiber boom.*



*Photo #6  
The Parts of the Gooseneck/Vang assembly:  
A - Hinge base grooved to fit on the mast. B - Hinge pin. C - Inner hinge. D - Left hand threaded clevis. E - Turnbuckle. F - Vang Adjustment Grip. G - Right Hand Threaded Clevis. H - Molded Carbon Fiber Boom.*

# Backstay Tensioner & Traveler



Top Left: Below decks, backstay tensioner servo. Middle: Above decks layout. Right: Drawing of the lines. All photos by Pete Maxson. Drawing by Jim Linville.

by Pete Maxson

For those classes that allow it, being able to alter the backstay tension remotely is a great go-fast addition to your boat. Maintaining the tension increases battery drain, as the servo is constantly under load.

The photos show rigging that decreases the load on the battery, while allowing ample tension adjustment. An adjustable yoke is created using plastic-coated wire. Attach the wire to a corner of the transom. Run it through one sheave of a double block, through a crimp, around a thimble, back through the crimp and through the other sheave of the double block to the other corner of the transom. A line is run from the shackle on the block, through a sheet-exit block to the servo. Pulling down on the block increases backstay tension.

Very little load is placed on the servo.

## Backstay parts list:

Wire: 50 lb-test coated fishing leader  
 Crimps: 1.6 mm (Great Basin Model Yachts #216)  
 Double Block: KDH (GBMY #254)  
 Sheet-exit Block: KDH (GBMY #255)

A remotely-adjustable mainsheet traveler has been used in the AC class for some time. The drawback was in the way it was set up. The skipper could move the traveler to leeward only, not to windward. The photos show a setup that allows movement both ways.

Harken sells a “mini” car and track system for big boats, but it is small enough to work on a boat the size of an AC.

The track goes across the deck where the mainsheet would normally exit and attach to the boom.

Two slots are cut near the ends of the track and sheet-exit blocks are inserted in the slots, through which lines

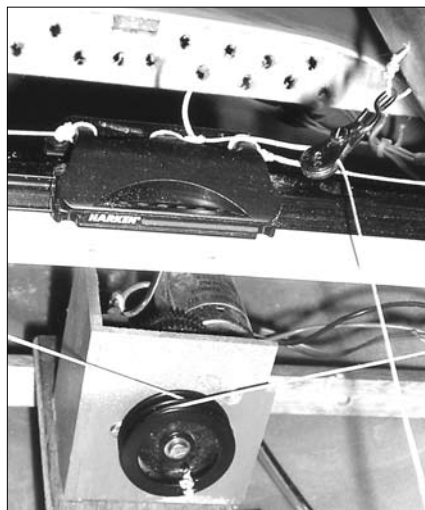
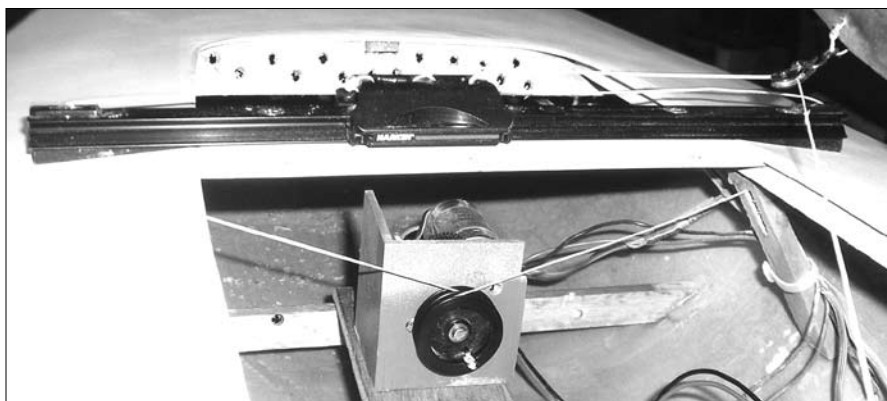
can be run to a drum winch (RMG 380HD). This allows for at least 4.5 inches of travel in each direction from the centerline.

There are two ways to attach the mainsheet to the car:

1. Have the sheet exit the deck near the mast, go through an adjustable block, down the boom, and attach to the car.
2. Create a slot through the middle of the track. Have the sheet exit the deck through this slot and through a hole that is drilled through the car itself.

## Traveler parts list:

Harken 2703 micro CB traveler Ti-Lite Car  
 Harken 2707 1m micro CB low-beam track  
 Sheet-exit Block: KDH (GBMY #255)  
 80# Spectra line: Cabela's  
 Servo: RMG 380HD Smart Winch



Above: Overview of traveler system. Right: Closeup of traveler car and winch.

# Single Channel Sail Control with Jib Sheet Fine Tune

(Or How Playing the Jib Works Too)

by Scott Spacie

Like Will Gorgen, in his most interesting article in *Model Yachting*, Issue 135, I too came from a people-boat background. Playing the mainsheet in a rail-down breeze offshore while working your way over waves is one of the greatest feelings in yachting. The same technique of fine tuning the main can be applied to model boats, however there are some cases where this might not be the fastest way to get an r/c yacht around a race course.

My sailing now is mostly done on the north shore of Long Island in an area known for its small ponds and light, fickle breezes. It is often more important to accelerate to the next wind shift and work your way through the 'dead zones' than it is to dump weather helm in a puff. My experience with my Venom 36 and Viper M, which have separate channels for jib trim, has shown me how helpful it can be to be able to play the jib instead of the main.

When the wind goes light it is good to be able to ease the jib slightly to reattach air flow and to open up the slot between the main and jib as the Reynolds numbers drop and the air gets more turbulent – all the time keeping the main leech firm to maintain helm balance. When the puff hits again, the relative wind swings aft and the jib often stalls. Easing the jib reattaches the air flow and helps the boat to accelerate. The relative wind swings forward as the boat comes back up to speed and the jib is trimmed back in. All this is accomplished without wasting precious energy by rotating the boat with the rudder.

Also, since my race courses here are restricted by pond geometry and custom, I usually sail a lot of reaches. In a close reaching situation, it is good to ease the jib more than the main to open the slot and promote air flow rather than it is to ease the main first which chokes off the air flow.

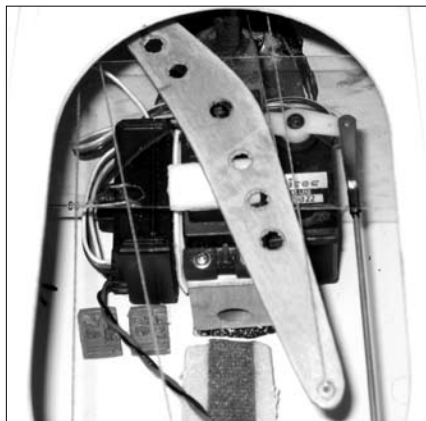
If the class you sail in doesn't allow the luxury of a separate channel for a jib trim or if you don't want to spend the extra weight of another servo, it is still possible to get a differential between the main and jib as Will explained in his article. My preference has always



Figure 1. Inside the author's ODOM showing the jib fine tune system the author uses for lighter winds. The view is looking forward with the mainsheet on the left and the jibsheet on the right. Photo by Scott Spacie.

been for a double arm sail servo on the basis of simplicity. I typically use about a 15 degree angle between the jib and main arms. The same effect can be obtained by placement of the dead ends of the sheets, but I find it is usually easier to place the dead ends near the sheet exits and let the angled arm provide the differential.

With this article are two figures showing the two different sheeting systems. Figure 1 shows the jib fine tune system that I use for lighter winds and Figure 2 shows the main fine trim system that is useful for heavier air. Both figures show boats looking forward with the main sheets on the left and the jibs on the right. They are both close hauled and the arms



Inside a Victoria with the mainsheet leading the jib. This fine trim system is useful for heavier air. The view is looking forward with the mainsheet on the left and the jibsheet on the right. Photo by Scott Spacie.

will go out counterclockwise as viewed from the top. Both boats use Futaba 3802 sail servos. Figure 1 shows an ODOM with the jib arm leading the main by about fifteen degrees. This allows the jib to go out sooner than the main. I don't usually set the boat up so that the main actually goes over center, but that is a matter of choice. My Soling 1 M is set up much the same way. Both these boats are (compared to a 36/600 anyway) overweight and underpowered. They have a tendency toward lee helm in light air and don't pick up weather helm very quickly as they heel. In heavy air, I just move the rig forward slightly and in a knockdown puff, easing the sheets quickly brings the boat back on its feet without use of the rudder. This boat did well in the 2002 Nationals in mixed conditions in spite of running aground twice and won a Regional in 2003 in light air.

Figure 2 shows a Victoria with the main leading the jib. I normally set the boat up as in Figure 1, but I have been experimenting with playing the main in the strong puffs of winter. The Victoria is an exciting boat to sail due to its light weight and relatively large sail area, but its keel is very short and provides limited stability. This, coupled with its wide beam, means that it picks up weather helm quickly as it heels. Easing the main a little as a heavy puff hits kills the weather helm effectively. I will probably go back to the Figure 1 setup for the lighter air of summer. It only takes a matter of minutes to change arms and re-lead the sheets but the hardest thing to do is to remind your left thumb whether you are fine tuning the main or jib.

Analyze the characteristics of your class of boats, the sort of race courses you sail on, and the typical wind conditions you sail in and then decide the best way to create a differential between your main and jib. Whether you use a separate channel for a jib trim or backstay adjuster or a single channel with main or jib fine trim, the goal is the same – to control the boat as much as possible with the sails and as little as possible with the rudder. The rudder can only slow the boat down. Practice taking your right thumb off the stick for a while and making fine course adjustments with the sail trim. I think you will be pleased with how much faster your boat will go.

# Hardware And Rigging

by Paul Proefrock

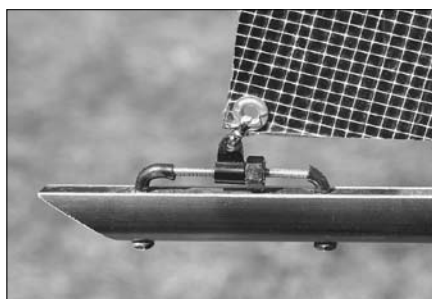
**W**hat'cha call that dang thing that adjusts the sail out? And how should I do it on my boat?

The fittings used on a sailboat have a very definite purpose; however the method to accomplish that may be varied. This outlines various fittings used on a typical EC12 sailboat. Except for the proprietary one-designs (Victory, SeaWind, CR914, etc), these are typical of all kit constructed sailboats.

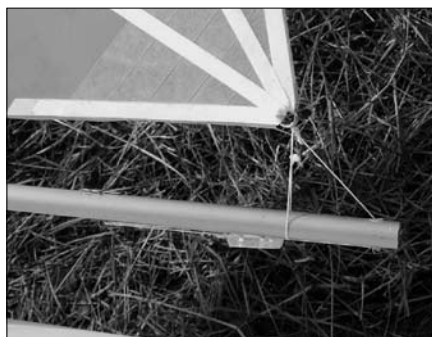
This article is short on words and long on pictures. If you need a larger view, all are available on the EC12 site: [www.proefrock.net/EC12Web](http://www.proefrock.net/EC12Web). A special thanks to Rick West, Mark Rinehart and all the EC12 drivers, allowing me to share their secrets with the world.

## Outhaul

The outhaul is used to adjust the draft (belly) of the sail.



*The outhaul of a mainsail can be as precise as this fitting allows (this is a copy of a outhaul fitting made popular by ProBar by in the 70's)*



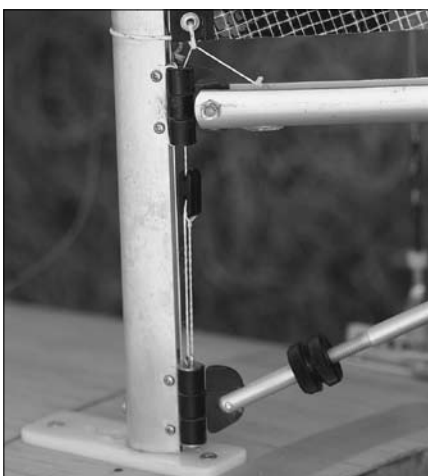
*Or as simple as this arrangement that uses line and a bowsie. One loop keeps the sail foot attached to the boom at the right height, the other serves as the outhaul, moving the tack back and forth.*



*And another method. All three do the exact same job – the choice is left to the builder/designer.*

## Downhaul

Used to tighten or loosen the luff of the sail, moving the draft fore and aft.



*This system evolved from the ideas presented in the Manual of the EC12.*



*This one uses a double purchase to give even more precise control of the tension.*



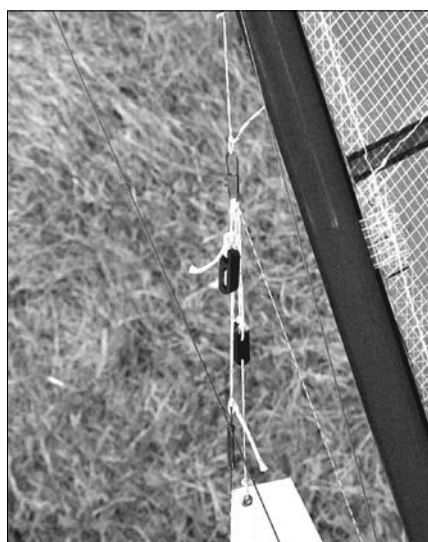
*Don't forget the jib, it needs adjusting also.*

## Jib head

If the Upper jib pivot is not free, the jib will not set properly, especially in light air.



*The rings and bowsies allow for attachment and adjustment. The cord facilitates the free rotation.*



*Yet another approach, doing the same thing.*



*This approach uses parts available from the local hobby shop to precisely locate the points of adjustment.*

### Fairleads

Getting the sheets out of the hull with minimal drag yet keeping the sea out the hull, not the easiest task. There are a number of commercially available fittings yet many make their own. An example



*Some see advantage in having the sheet near the boom, hence some more exotic arrangements:*

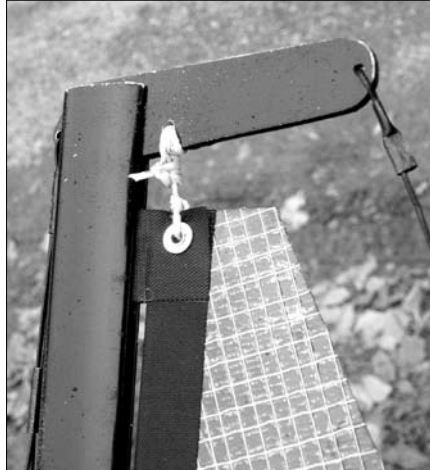


*Often blocks are used in conjunction with the fairlead, to decrease friction.*

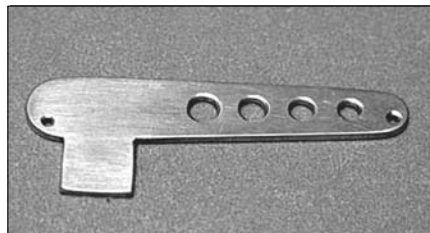
*Right: Using the forces generated by the backstay, this model incorporates a pivoting mast crane. The tension generated by the backstay is translated into vertical forces, thereby reducing mast bend.*

### Mast Crane

The mast crane does a little more than attach the backstay. Used properly, it is a major tool in controlling mast bend.



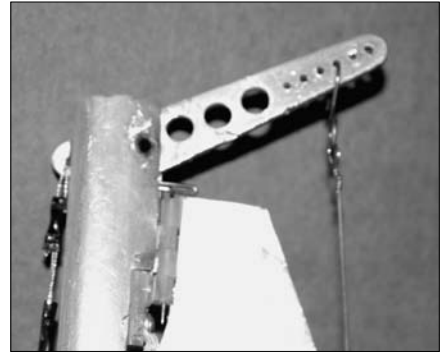
*The simplest mastcrane is a flat piece of material, rigid enough to withstand the forces it encounters.*



*This approach is "bettered one more" by a fitting available from one of the class suppliers.*



*Another inventive modeler is using an extruded shape then modifying it to a streamlined shape. Very light, very strong.*



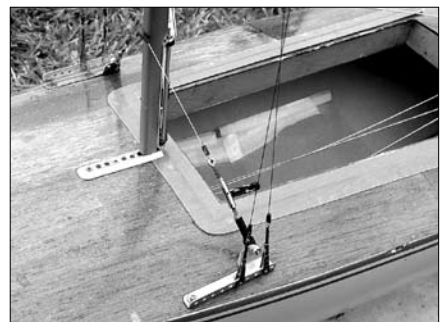
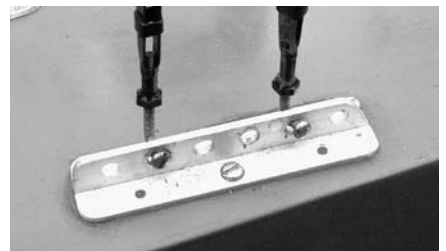
### Mast Base

The mast needs to be adjustable fore and aft to change helm, but needs to be retained left/right (port/Stbd). Most use a pin in the bottom of the mast mated to a plastic or aluminum plate fastened to the centerline of the hull. (Note, I said centerline. If off center, it will cause your boat to handle differently on each tack).



### ChainPlates

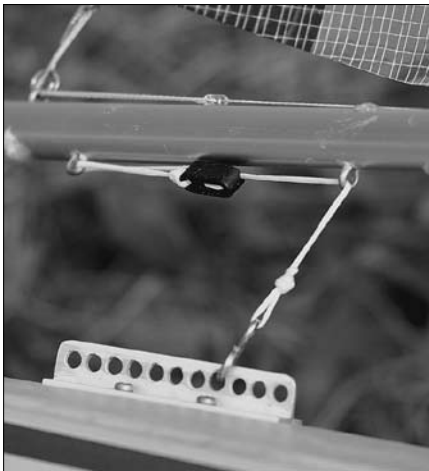
The shrouds connect to the side of the deck. The fastening not only anchors the shroud, the position is used to control mast bend.



*Another design adds a tie-off point for a set of lower-lowers.*

### Jib Rack & Jib Pivot

The jib rack fastens the jib pivot point to the foredeck and allows fore/aft adjustment of the entire rig.



*Having a bowsie or other adjustment allows change in the length of the jib pivot, allowing for a change in mast rake.*



*This approach also allows adjustment of the position of the jib pivot point on the boom.*

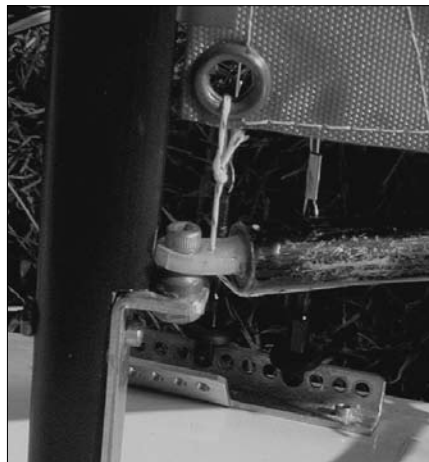
### Backstay Anchor

You need a solid anchor at the rear of the hull to anchor the backstay.

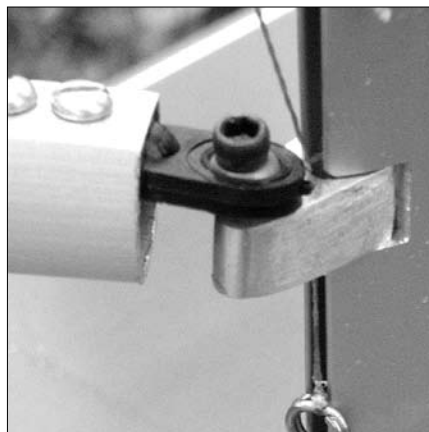


### Gooseneck

Ah, the fun begins. With only a single purpose, this item has more designs than your local pharmacist has pills.



*This design uses a formed metal bracket with a ball joint available from most hobbyshops.*



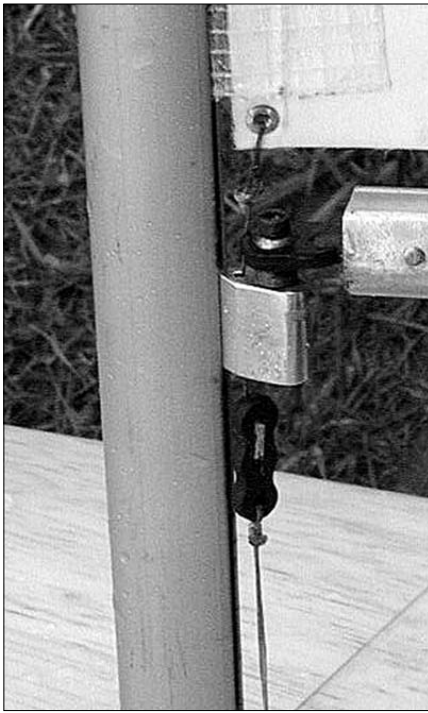
*A special made piece to fit into the standard aluminum mast. This also uses a standard ball link.*



*This approach also uses a ball link but a different method to attach to the mast.*



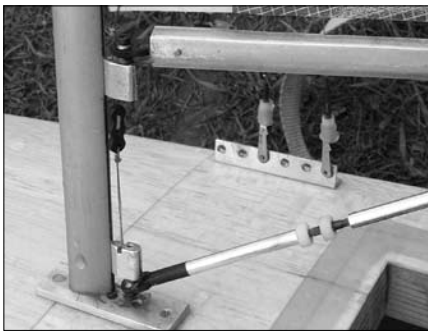
*This modeler widened the groove slightly on the aluminum mast to accept his own custom made gooseneck fitting. Again, a ball link end for the boom.*



*This gooseneck uses a ball link and a standard fitting available for the Gold-spar mast.*

### Vang

The vang holds the position of the mainboom as it pivots thru its range. Some vangs are a solid piece, others use cord or springs to allow some downward movement but not upward.



*Below: This vang uses a spring to hold the boom up and an eccentric system to change the angle of the boom, depending on its distance from the centerline. Very Hi-Tech.*



### Jumper Struts

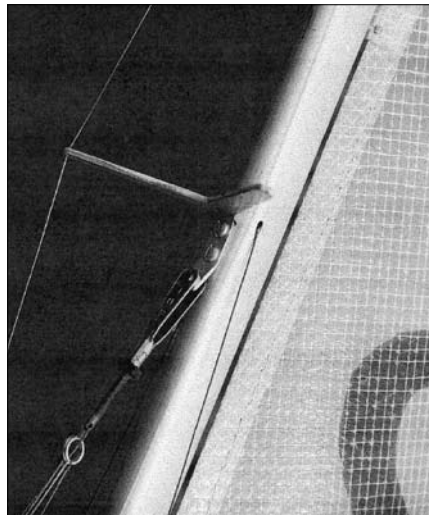
Many designs use a jumper or jenny strut to control the upper mast bend.



*A couple of different approaches. This one is removable for transport.*



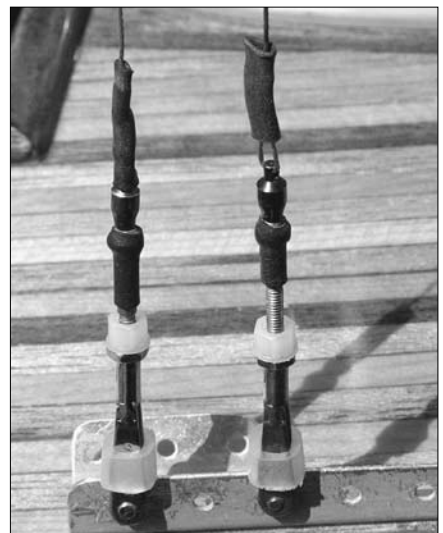
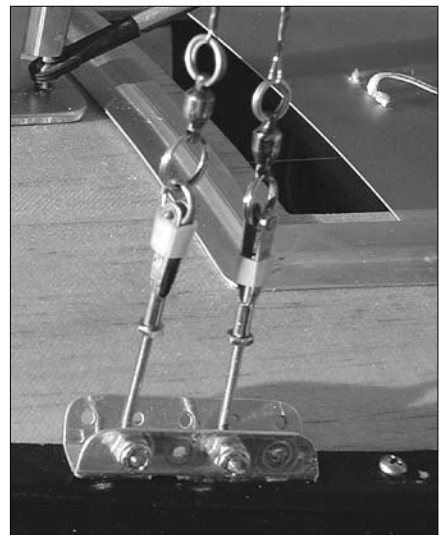
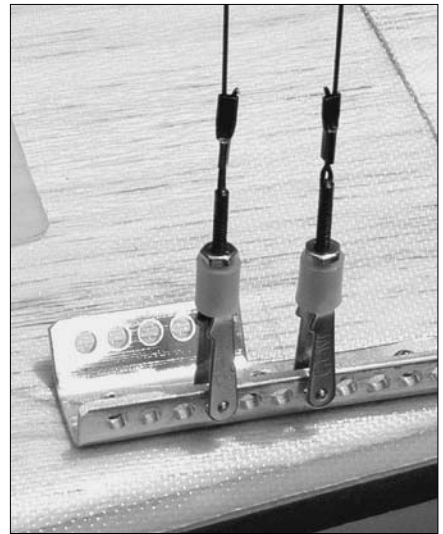
*This strut is fixed but very low exposed area. You really need to look close to see the struts – they're small.*



*This strut combines the anchor point for the forestay.*

### Shroud Adjustment

This can be as simple as the fancy "pelican hooks" provided by some European suppliers. (pretty but heavy) to some modified quick-links from your local hobby shop. Even with those, there are different ways of doing it.

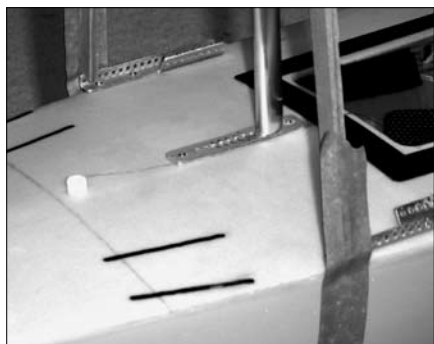


Also a part of rigging a boat are the special fixtures that some modelers use.

### Mast Divider



*Used to stand the mast vertical to the hull*



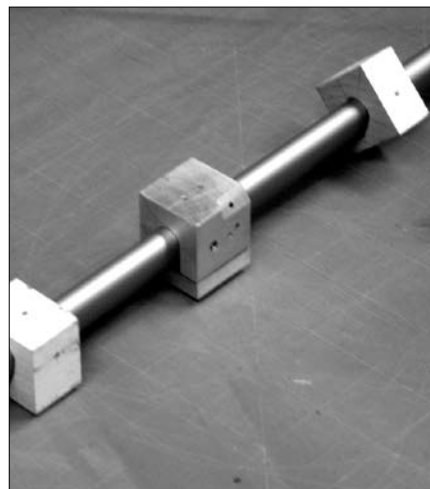
*The base rests on the chainplates,*



*The top snaps to the mast. If both legs are equal length, then the mast will stand vertical (Remember your geometry 101? And you thought you'd never have a use for it?)*

### Drill Fixtures

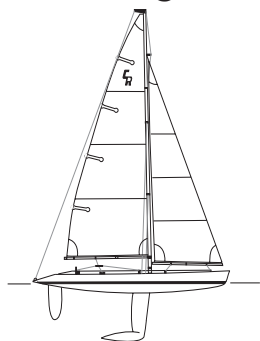
Holes in the mast for shrouds and spreaders need to be at specific locations and angles to perform the best. Here, some simple aluminum blocks are machined to fit the mast, with holes at the prescribed angle.



Surely, you spend as much time on your boat, don't you? This isn't the reason that some skippers win all the time but when the better skipper also has the better boat, it is a pretty formidable match. If you'd like to see more ideas and images, check the internet site [www.proefrock.net/ec12web](http://www.proefrock.net/ec12web) The only charge is that you share back any ideas you have.

## CR-914

One Design



## Chesapeake Performance Models

- ONE PIECE MOLDED HULL AND DECK
- PRE-CUT SAILS
- TWO PIECE ALUMINUM MAST
- CAST LEAD BULB
- GREAT CLASS ASSOCIATION

Chesapeake Performance Models — 227 Main Street. — Stevensville, MD 21666

Phone: 410-604-3907 — Fax: 410-604-3908 — [www.rcyachts.com](http://www.rcyachts.com)



# Skalpel Running Rigging

by John Davis

I returned to model yacht racing a few years ago after a long absence, and the first boat that got my attention was a Marblehead called the Skalpel. I served as 50/800 Marblehead Class Secretary back in the early 80's, and the dominate boat back then was called Epic. As I read the past few years of *Model Yachting*, Skalpel had really defined what dominate boat meant, so I couldn't resist learning more about the boat. Des Moines, Iowa is a great place to live, but we are a bit limited in model yachting resources. I was fortunate to have a two week business trip to Irvine, California, and meet John Castelli, a member of the Woodbridge RC Yacht Club, #71. John races IOM's and Marbleheads, and John wins races. I am fascinated with fast boats with great hardware, but boats don't win races—skippers win races. That said, John took the time to show and explain the workings of the Skalpel and allow me to get the photos for this article.

A well designed boat is a thing of beauty, but a well designed and well engineered boat is beyond that ideal, and the Skalpel is surely engineering excellence with matching performance—the boat is a wonder. Using only three servos, the boat incorporates control under way of the rudder, main and jib sheets, jib sheet tuning, main and jib clew outhaul, cunningham, backstay tension, and moving the jib club opposite the main boom for consistent downwind wing-on-wing aspect.

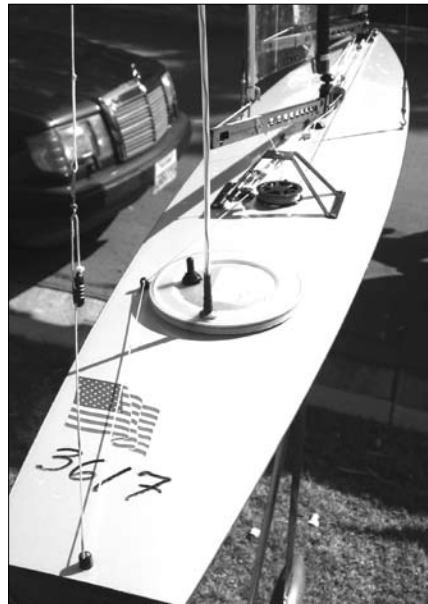
At first glance, the maze of control lines on the deck looks confusing and you just know they will end up in a tangled mess. The lines do not tangle, and the boat is rock-solid reliable. As you understand the function of each line, and see how efficient the placement and action is, you gain a new appreciation of the term “elegant”. We can learn much from the different elements in the design of this boat's running rigging, so the following pictures attempt to isolate different lines and show their function.

We will start with a series of overview photos of John's Skalpel. Then we will use black paper between the white

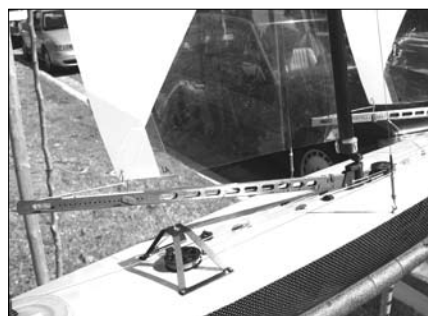
lines and the yellow deck to more clearly see the path of each line. This will



Bow view. Photos by John Davis, except as noted.



Stern view...

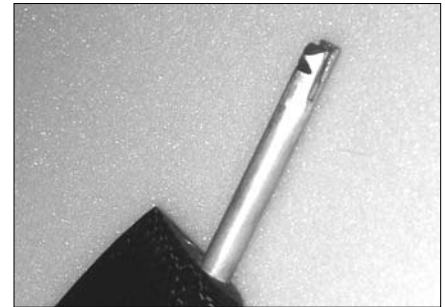


Starboard side.

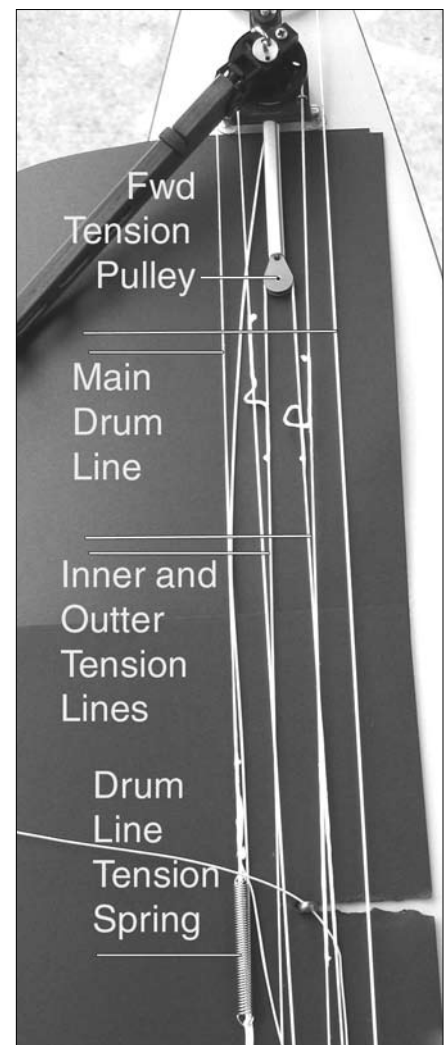
look a bit confusing at first, but it is necessary to see the path of each line.

Rudder control is from a standard servo with a unique quick-disconnect rudder post that allows quick removal of the rudder for safe transport.

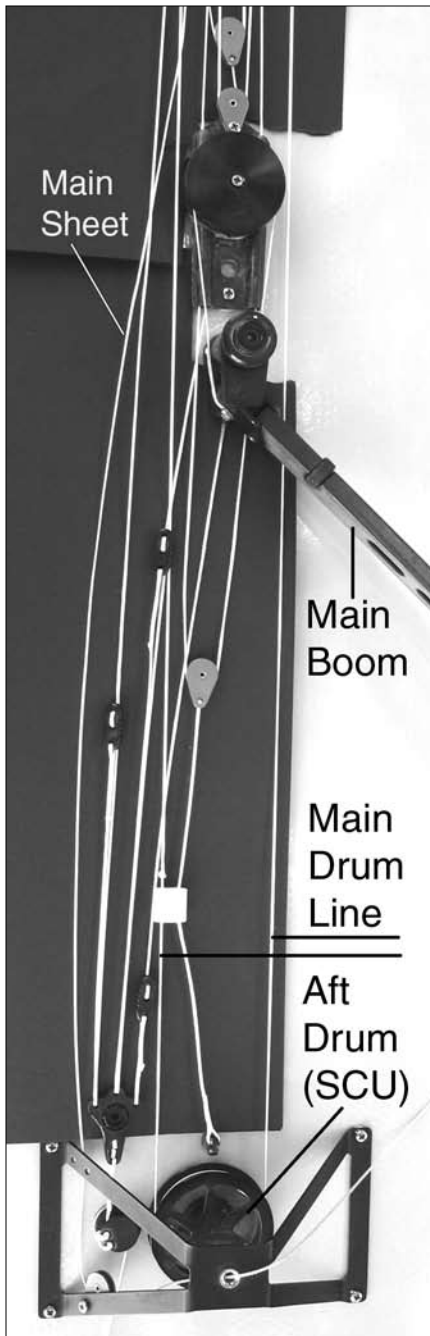
Sail control is from a drum winch



Note the notch and slot at the top of the rudder post which allows alignment of the rudder as well as quick removal for transport. This photo by John Castelli.



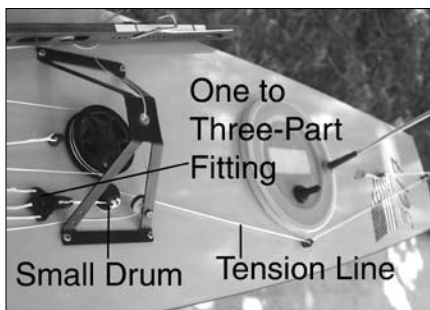
Forward section of the drum line...



*Aft section of the Main Drum Line.*

with the Main and Jib sheets attached to the continuous main drum line.

Backstay tension is controlled from the small third servo drum to port of the main/jib sheet drum. As

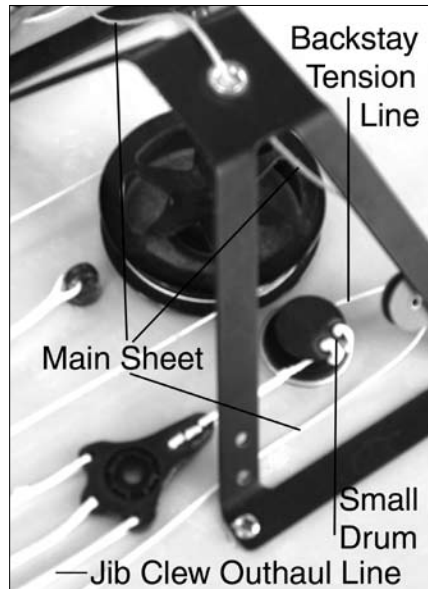


*Backstay Drum and tension line.*

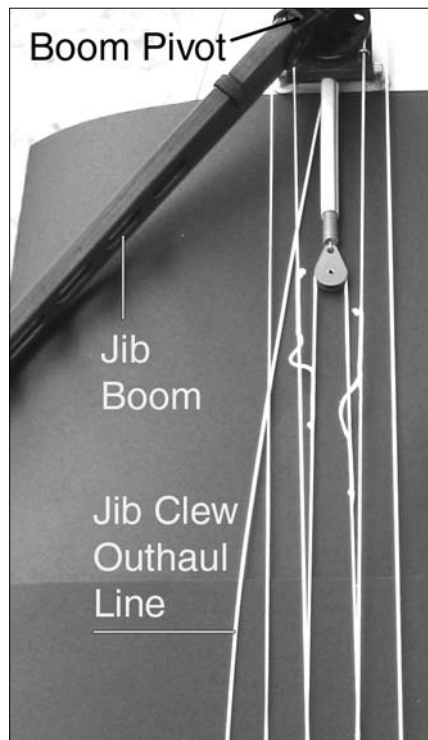
the drum rotates, the backstay is loosened or tensioned.

On the other side of that small third servo drum is another line leading forward that is multiplied by a three-part fitting controlling three lines.

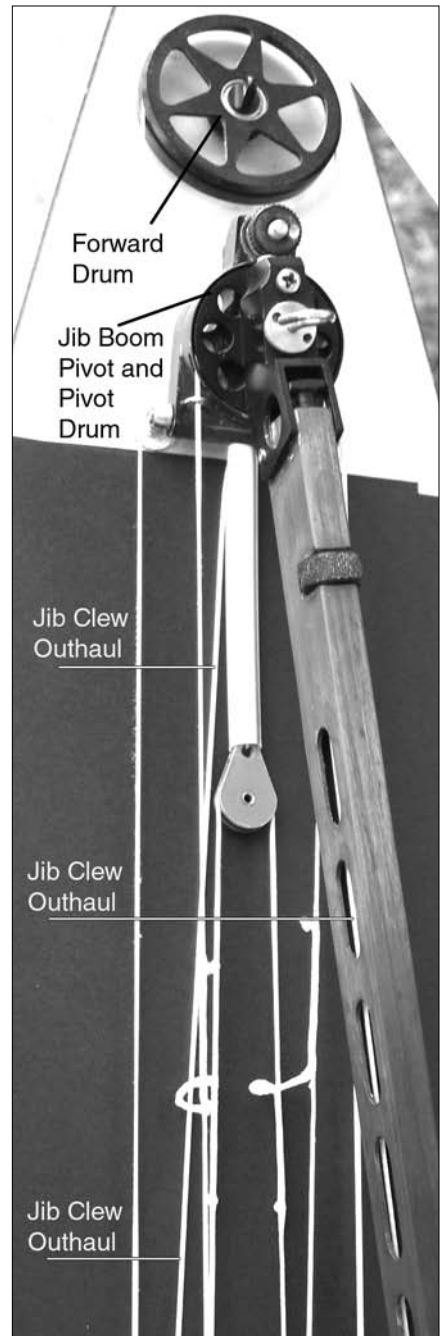
The first of those three lines (the outboard line) controls jib outhaul. The first of these lines for jib outhaul is lead on the deck to the bottom of the boom pivot, through the hollow carbon-fiber boom to a turning block at the end, then back to the levered



*Jib Outhaul line and drum...*



*Jib Outhaul Line through the Boom Pivot and the Jib Boom to the Pivot Block, then the Clew Outhaul Pivot...*



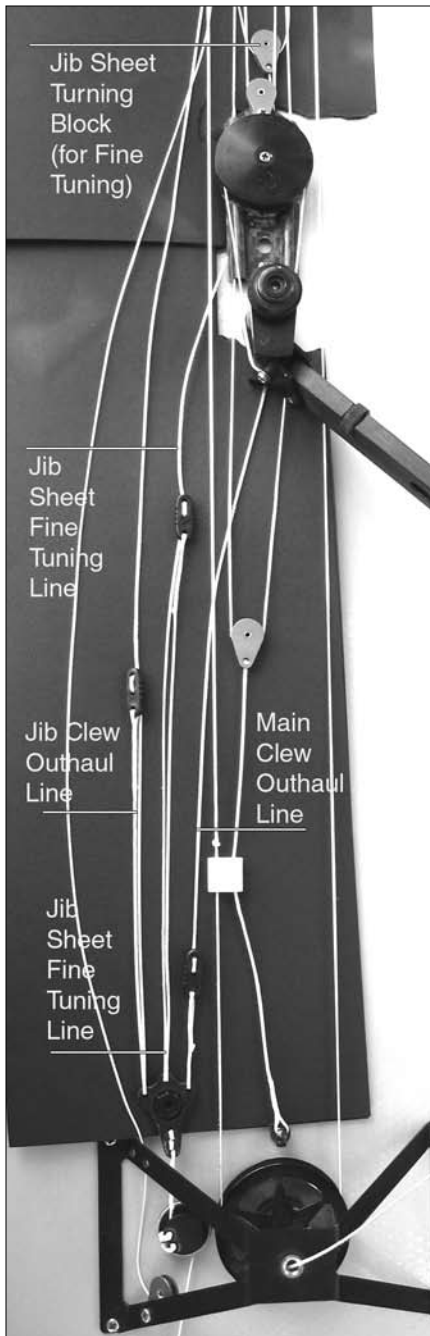
*Another view of the Jib Outhaul on deck and running inside the Jib Boom back to the outhaul pivot arm.*

arm that hooks to the jib tack for outhaul control of the foot of the sail.

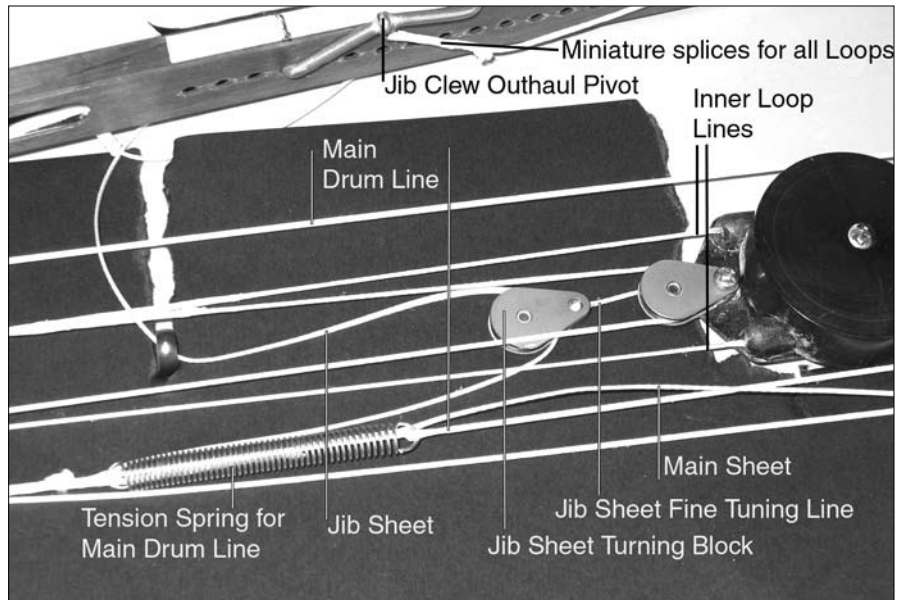
The second line is routed on deck under the butterfly mechanism, to a block that turns on the jib sheet and effectively tunes that sheet by lengthening or shortening its travel distance.

The third of those three lines controls main outhaul in the same manner as the jib outhaul.

Now we come to the "Butterfly", a spring-loaded mechanism that moves the jib club opposite the main boom for reliable wing-on-wing downwind

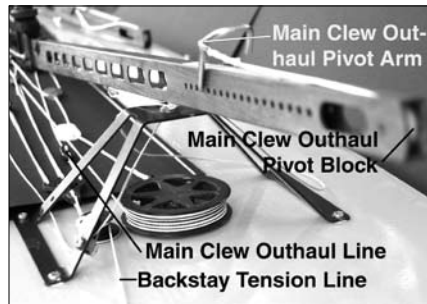


The second line routed to fine tune the Jib Sheet by a block that shortens or lengthens its pulling distance...



A close-up view of the Jib Tuning Block and Sheet. You can see where the Jib Sheet and the Main Sheet attach to the Drum Line. The spring maintains tension on the Drum Line. Also, note the Jib Outhaul Pivot near the end of the Jib Boom.

performance. The Butterfly is activated when the main boom is full out, pull-



The Main Outhaul works like the Jib Outhaul by routing through the Boom Pivot, then out to a turning block on the end of the boom, then to an Outhaul Pivot Arm that attaches to the Clew of the Main sail. One servo turns a small drum that controls four functions to adjust sail shape to allow for different wind conditions encountered while racing.

ing on one side of the Butterfly with a line attached to the boom. At the same time a knot in the Main Drum Line pulls a block of a line lead forward to another block attached to a spring attached to the aft side of the jib pivot. There is another loop of line from a block attached to the forward side of the butterfly that drives the pivot pulley at the jib pivot. These two loops of lines are spliced at a point port and starboard that pull the jib pivot out. Depending on which side is opposite the main boom, the action of the butterfly, combined with the tension on these lines at the splice point, force the jib to a wing-on-wing position.

Study the photo's. Are these ideas too complex, or simple enough to apply to your boat? Elegant design that achieves maximum control with only three servos—that's all there is to it!



## R/C YACHT CARRIERS

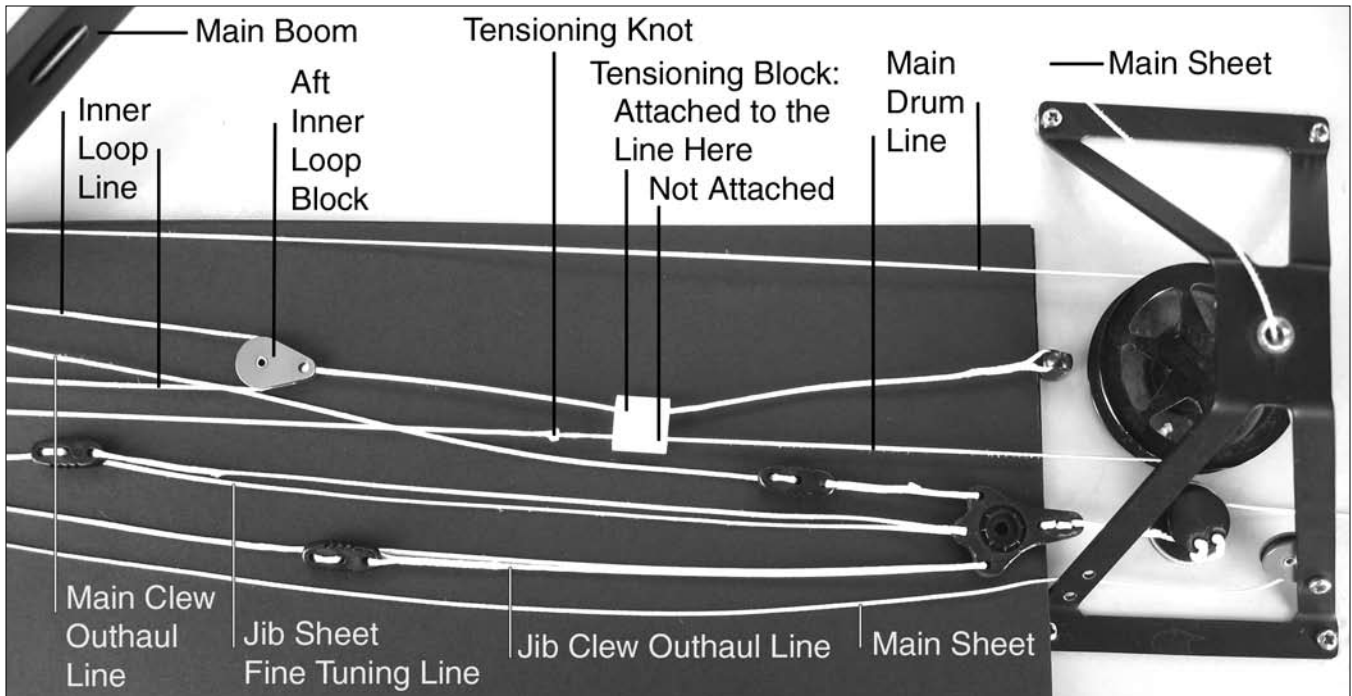
CARRY ALL; QUALITY SHORE BOX FOR BOAT, TRANSMITTER AND GEAR.

BOAT TOTE: UNIQUE FOLDING CARRY CRADLE.

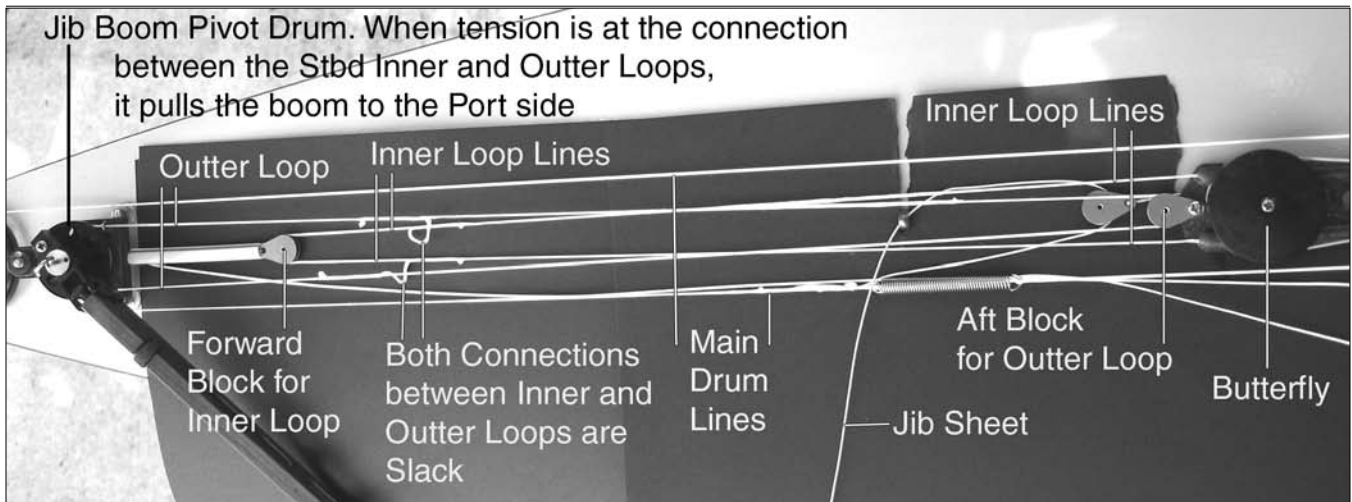
**CONTACT: R/C CONCEPTS**  
**5251 Wentworth Rd**  
**Port Charlotte, FL 33981**

**PHONE: 941-697-0951**  
**E/M: rmaiese@netzero.net**





At a beat to windward or while reaching, the Main Drum Line has not let out the Sheets far enough for the knot to reach the Inner Tensioning Block. The Drum Line runs freely through the port side, and the Inner Tensioning Line is permanently attached to the starboard side. It is out of view of this frame, but the Main Boom has not pivoted far enough to activate the Butterfly.



At the bow, the Jib Boom is in a normal upwind position. The forward block of the Inner Tensioning Line is retracted, so that Inner loop of line has no effect on the Outer loop which turns around the Jib Boom Pivot Drum

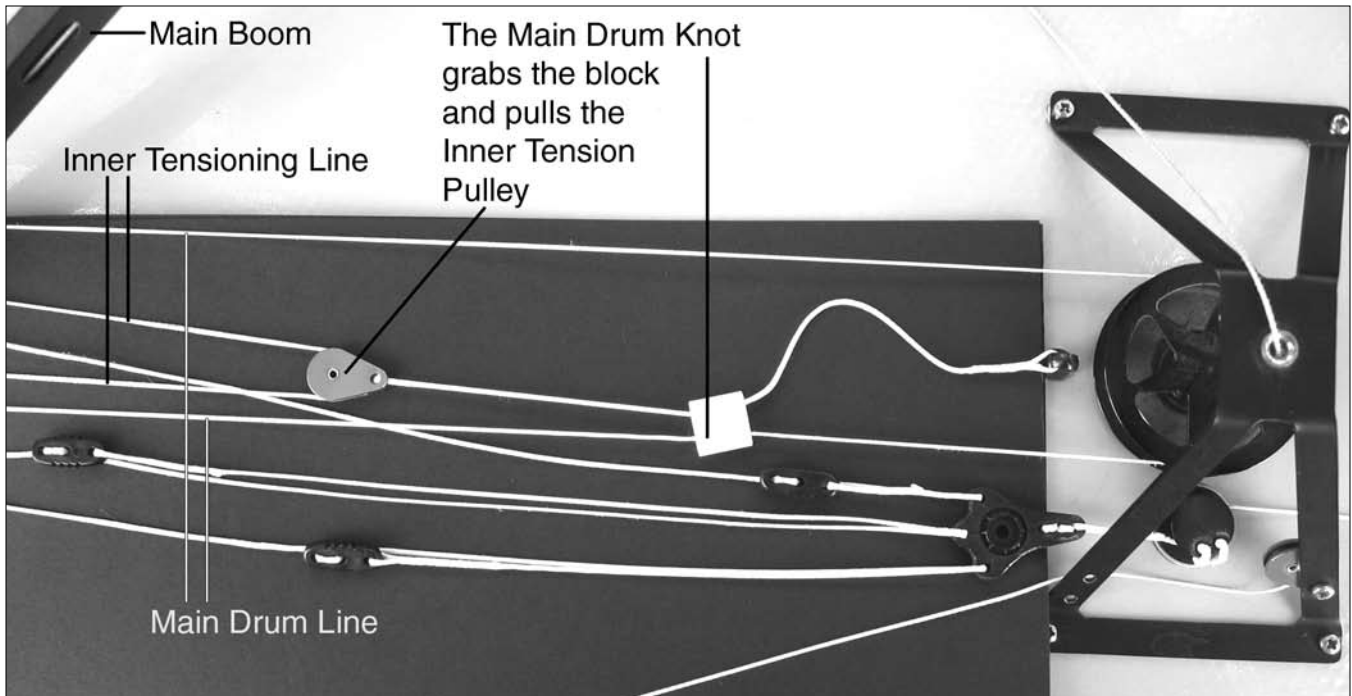


## **SIMPLIFY YOUR VICTORIA ASSEMBLY**

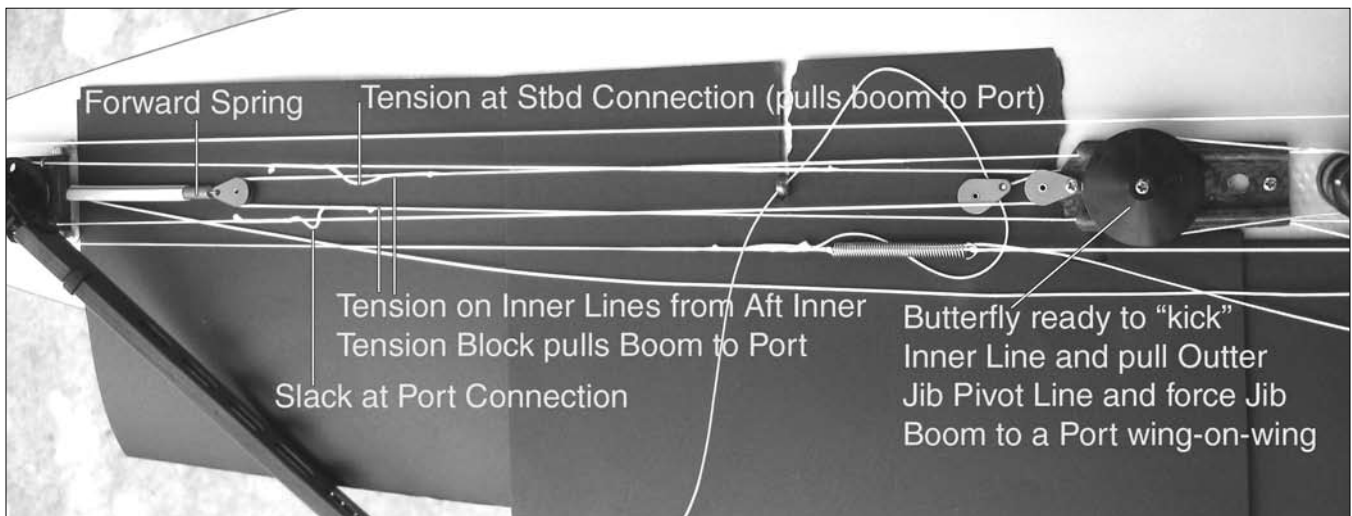
Kit from **Anchor Bay Specialties** provides bulkhead, servo tray, Rx /Batt tray. Cut, trim, then glue in place.

\$19.95 plus S&H  
See web site for details.  
[www.anchorbayspecialties.com](http://www.anchorbayspecialties.com)

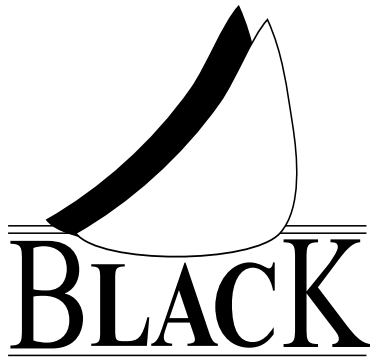




*As the Main Drum Line lets out the Main and Jib Sheets to the Running position, the knot in the line pulls the Inner Tensioning Block, which in turn, pulls the aft Inner Tensioning block/pulley. This loop passes through the bottom of the Butterfly.*



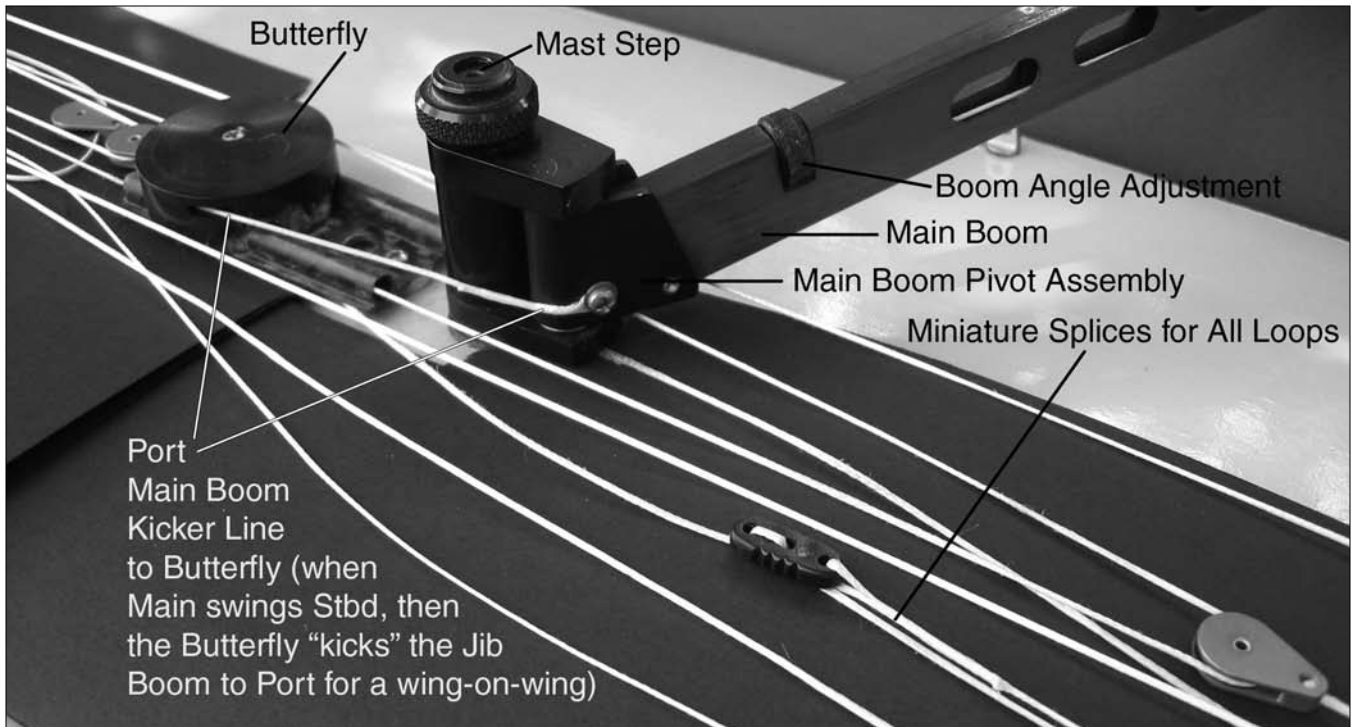
*As the Inner Tensioning Line is retracted, the forward spring is visible and under more strain, and a short piece of line attached to the Outer Loop is put under tension starting to bias the Jib Boom Pivot Drum so that it will only pivot in the direction opposite the Main Boom.*



## Black Sails

*Sails: the most important factor in high performance  
Get new sails and see the difference!*

2003 Bayview Heights Drive #58, San Diego, CA 92105-5528  
Phone: 619-263-0809 [rcmdlboat@aol.com](mailto:rcmdlboat@aol.com)



*As the Main Boom swings all the way to the starboard side (in this photo), the line attached to its port side pulls far enough to activate the Butterfly, and it applies a momentary "kicking action" to the Inner Tensioning Line, causing it to pull the Outer Jib Pivot Line (where the two are attached) even further, and forcing the Jib Boom into a wing-on-wing position opposite the Main Boom. The bias on the Outer Line where it is attached to the Inner Line keeps the Jib Boom in this position. Actually, because of the tension on one side of the Inner and Outer Loops, this system would work to force a wind-on-wing on some boats, without the Butterfly mechanism. This is a delicate balance, and the Butterfly serves to effectively "tip that delicate balance" in the direction of a proper and ready wing-on-wing of the Jib and Main Booms..*

# LASER

## Hitec's New 4 and 6 Channel 75MHz Radio Systems

Get More and Pay Less With Hitec's Affordable, Feature Packed Laser Radios.

Both Systems come complete with: Two HS-322 servos, one 8 Ch. Supreme receiver, transmitter NiCad batteries, one CG-25 "overnight" A/C charger, AA "dry" receiver battery holder, and Hitec's "Two Year" Warranty

Laser 4 Ch. # 156751

Laser 6 Ch. # 157751



**HITEC**  
TOUCH YOUR DREAMS

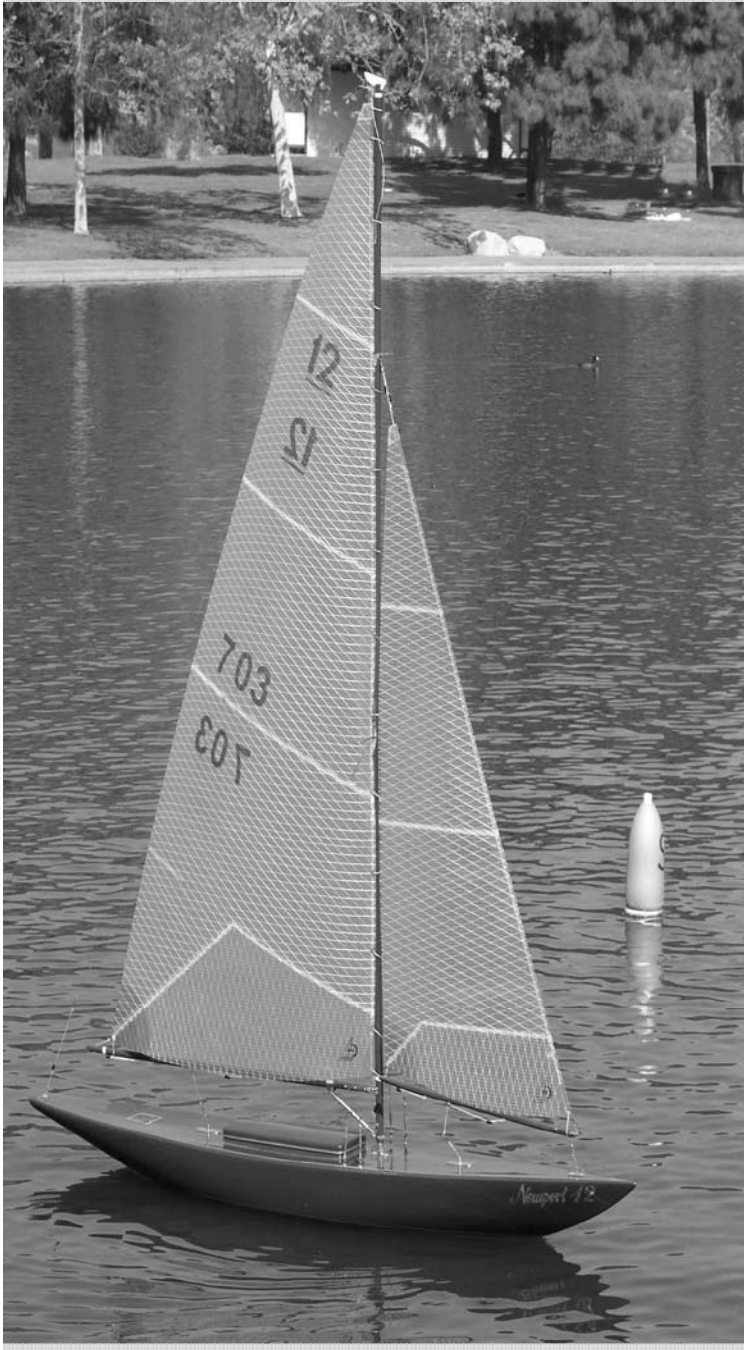
12115 Paine Street, Poway, CA 92064 (858) 748-6948

# AMYA MEMBERSHIP SPECIAL

RED-WHITE &  
BLUE SPECIAL

## SPECIAL OFFER

*"All Newport 12 purchases include one year AMYA Membership and Class Registration"*



## Newport 12

### R/C Sailboat

**700 'B' Series** - Comes manufacturer assembled w/interior bulkheads, deck, interior braces for mast—jib rack—backstay padeye, and with main & rear deck hatch covers, construction prints, rudder, construction prints, assembly rack. High gloss gel-coat.

3 Available - Red / White / Blue

**Catalog List Price \$949**

**Red-White-Blue Special \$ 525**



**700 'A' Series** - Modelers Special: Comes with high gloss gel-coat hull, deck, main & rear deck hatch covers, construction prints, assembly rack, rudder.

8 Available - Red / White / Blue

hull w/ matching hatch covers & white decks

**Catalog List Price \$749**

**Red-White-Blue Special \$ 349**

(+ shipping/handling)



**LOA:** 72.0 in • **BEAM:** 12.0 in • **LWL:** 51.5 in • **Hull Material:** Fiberglass •  
**Mast:** Spruce 79"—81" • **Displacement:** 38 to 42 lbs. • **Total Height- Keel to Mast Head:** 94.5 in • **Scale:** 1/12th • **Rigging:** Coated Wire • **Sail Area:** 1582.5 sq in • **Finish:** High Gloss Gel-coat - Requires sail winch & 2-Channel radio •  
Visit the Hanna Boats website for complete hardware and accessories.

*All Hanna Boats Newport 12 purchases come with 1 year  
AMYA Membership & Class Registration*

702-767-2639



Master Card  
Visa/Discover  
cards accepted

[www.hannaboats.com](http://www.hannaboats.com)

© Copyright 2004—HannaBoats

# Single Channel Sail Control with Main Sheet Fine Tune

From Issue 135

By Will Gorgen

Steering an offshore racer to windward requires close communication between the driver and the mainsail trimmer. As the boat heels up in a puff, the center of drive of the sails becomes offset laterally from the center of resistance of the hull causing the boat to develop windward helm. Fighting that helm with rudder control alone is very slow. As the helmsman feels the helm building he will signal to the mainsail trimmer to de-power the main. Depending on the boat, this can mean dropping the traveler down, easing the sheet, or even cranking on the backstay to flatten the sail and add twist to the upper portion of the sail. At the same time the jib trimmer will leave his sail alone.

De-powering the main accomplishes two things; it reduces the heel of the boat and it changes the balance between the jib and the main. Reducing the heel of the boat will reduce the moment trying to head the boat up into the wind. Keeping the jib trimmed

in while the main is eased causes the center of effort of the sails to shift forward of the center of lateral resistance producing a moment that tries to head the boat down. If done correctly, the combination of these two effects can negate the windward helm allowing the boat to maintain its course with no drag producing rudder pressure.

The physics causing windward helm on RC boats is the same as it is on full sized boats. So we should want to react to it in the same way – by easing the main while keeping the jib trimmed in. On the Fairwind class boat as with many other RC classes, sail control is limited to one channel. However, through clever geometry, it is possible to allow the main sheet to be eased and trimmed while the jib trim remains virtually unchanged. This can be accomplished in various ways on both drum winches and arm winches. I use a single arm winch in my boat, so the figures show the how to rig the sheets for that type of winch. But the same principles can be employed with a double arm winch as well as a drum winch with a scroll drum.

The trick lies in “over centering” the jib sheet. By this, I mean that the sheet is lead to the swing arm in such a way that the arm passes through the point of maximum trim (when the arm is pointed directly away from the sheet lead) and actually begins to ease slightly. Others have used this concept before. A swing arm with multiple jib attachment points, which could allow varying degrees of over centering, is shown (with little explanation) in the US One Meter construction manual. However, I have not seen any arrangement that allows for as much difference in jib and mainsheet movement as I have designed into my system.

Diagram 1 shows the basic sheeting arrangement. The main sheet is led to the servo directly from a fairlead in the deck. The jib sheet is led from the foredeck fairlead to a turning block aft of the servo and then to the servo. Due to packaging limitations (beam of the boat) the swing arm cannot be as long as it needs to be. So a pulley is fixed to the end of the swing arm which the sheets pass through. The sheets are then dead ended (with bowsie adjustments) as

shown. The pulley on the swing arm simply increases the amount of sheet travel possible. If a longer swing arm would fit in the boat, it would be possible to eliminate this pulley. An additional turning block is added on the bitter end portion of the mainsheet which can be moved fore and aft to adjust the sensitivity of the system.

Diagram 2 shows the same system with the swing arm trimmed to a close hauled setting. In this orientation, the jib sheet is aligned with the swing arm. Thus, movement of the swing arm a few degrees to either side of this position will produce negligible change in the sheet length. The main sheet, by contrast, still has a substantial angle between the sheet and the arm such that movement of the arm will result in trimming or easing of that sheet.

I used a spreadsheet inspired by Lester Gilbert (UK IOM Sailor who maintains a very good technical reference on RC sailing at [www.onemetre.net](http://www.onemetre.net)) to design my sheeting geometry. I used Lester’s format for the geometry above the deck (jib pivot location, sheet

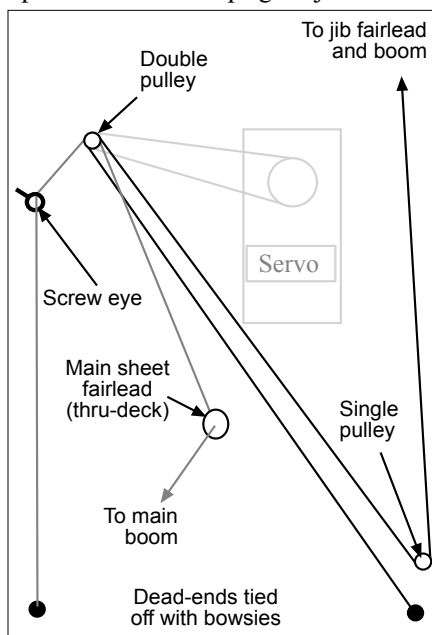


Diagram 1. The Basic Arrangement. The jib sheet (black) is led to the servo from the starboard transom. The main sheet (grey) is led to the servo directly from the main sheet fairlead. The screw eye can be moved fore and aft to adjust the geometry of the sheeting system before it is fixed in place.

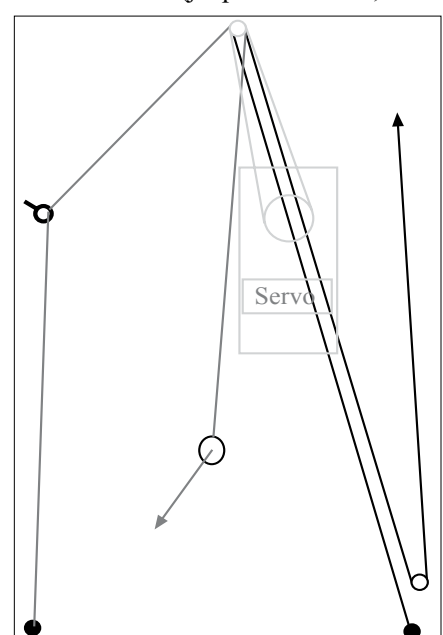


Diagram 2. The Closehauled Position. The servo arm is in the middle of fine tune travel with the coarse tune all the way in. Note that as the servo arm swings more closed the main sheet will continue to trim, but the jib sheet will not. In the small range of fine tune adjustment the jib will trim in or ease while the main will not.



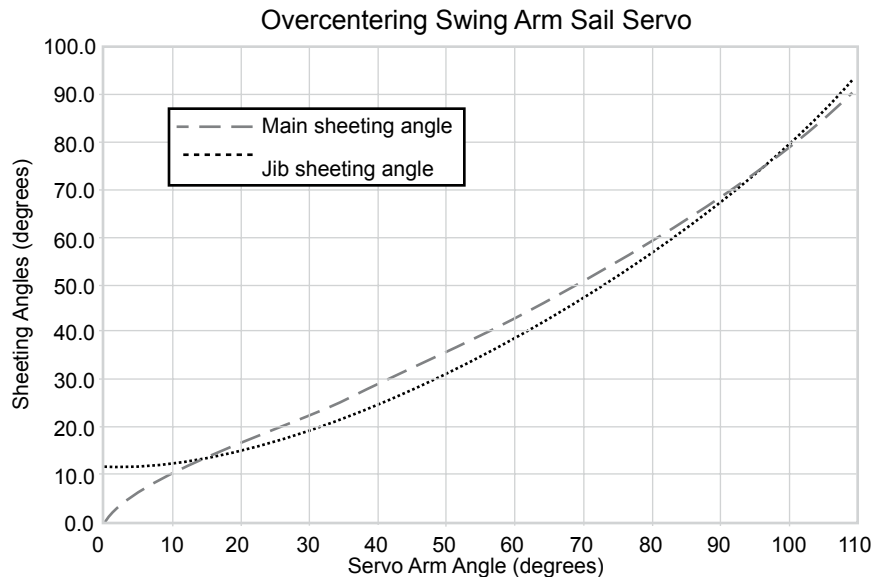
(servo arm length, sheet turning block positions, etc). The combined geometry allows me to calculate the sheeting angle (angle of the jib and main booms to the boat centerline) versus servo arm angle. I played with the locations of the mainsheet and jib sheet turning blocks as shown in the diagrams until I achieved the desired result.

The overall result is shown in Graph 1. The two traces in this graph show the sheeting angle of the main boom and jib boom. Over the sheeting angle range from about 30 degrees to 90 degrees (reaching and running sheeting angles) the jib and main are nearly parallel as shown by the fact that the sheeting angles are nearly equal.

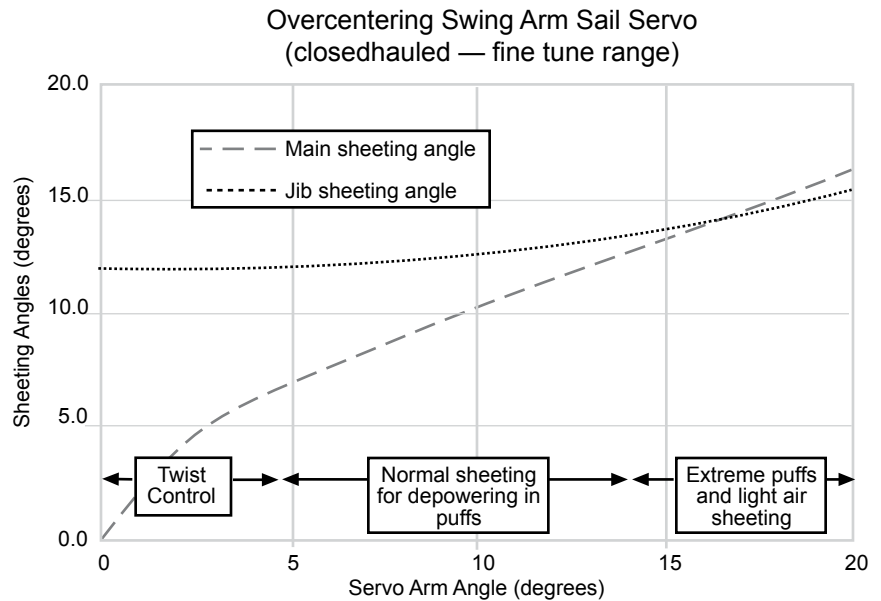
Graph 2 shows a zoomed in view of the servo angles used for close hauled sailing. It is clear from this graph that the jib sheeting angle stops changing and in fact slightly reverses as the servo is trimmed in due to the over centering effect. At the same time, the main sheet is continually changing as the servo trims in. An added feature of this system is that the final few degrees of trim in theory cause the main sheeting angle to drop to zero. In fact this does not happen. Rather, the sheet pulls down on the main boom allowing me to overcome the vang tension and tighten the leach to control the twist of the sails.

The 20 degree range of servo movement shown in Graph 2 is the angle range that can be changed using the fine tune slide on my transmitter. Thus, when I am racing, I move the stick to the fully trimmed in position and then use the fine tune slide to ease and trim the main to affect the balance of the boat. When sailing downwind, I slide the fine tune all the way out to get the sails out to 90 degrees. Then, as I round the leeward mark, I trim in using the stick and the sails come in to an eased out close hauled setting. That way, the sails are not over trimmed as the boat comes up to course. Once the boat is settled in on the upwind heading, I can bring in the sails using the fine tune until I feel the helm balance out.

This system works so well that during the final race of the 2002 Fairwind National Championships, I was able to sail the final windward leg without touching my rudder stick on my radio except to tack. The wind strength was relatively steady with the puffs building and subsiding gradually. I was able to respond to these puffs by easing the main slightly to keep the boat on course and then trimming back in as the wind strength subsided. These changes in main sheet trim allowed me to steer the boat with the balance of the sails rather than the rudder. I had rounded the final leeward



Graph 1.



Graph 2.

mark with a several boat length lead in the race, but by the time I reached the finish, I had extended my lead in the race to nearly half a leg. There were really no wind shifts during that leg, so I am convinced that my increased margin of victory was due to the reduced drag of steering with the sail trim rather than with the rudder.

As I mentioned earlier, this system can be used with a double arm or drum winch. The US One Meter construction manual (available online at [www.modelyacht.org/us1m/us1mcons.html](http://www.modelyacht.org/us1m/us1mcons.html)) shows a double arm sail winch with the jib arm at an offset angle to the mainsheet arm. This offset would allow the jib sheet to over center just as my single arm system does. Through careful geometry of how the jib sheet is led to the arm, the angle between the mainsheet and

the arm can be large enough to allow for further sheeting after the jib over centers. With a drum winch, it is a little more difficult to accomplish this effect, but it can be done. The jib sheet and main sheet would need to be led to the drum as separate sheets. A step-down or scroll drum would need to be used so that speed of the jib sheet trimming would be reduced to a very low speed at close-hauled while the main sheet was still being sheeted on the larger drum. The clever designer should be able to come up with other ways to accomplish the basic principle of over centering that makes this system work. A version of the spreadsheet that I used to design my system is available for download from Lester Gilbert's site: [www.onemetre.net/Build/Armwinch/armwinch.htm](http://www.onemetre.net/Build/Armwinch/armwinch.htm) that can be used as a starting point for your design.

# Spektrum DX6 R/C System

The answer to frequency conflicts

From Issue 142

by Chuck Winder

In the January 2006 issue of Model Aviation there was an ad for the new R/C radio system operating at 2.4GHz. "Spektrum" is a new brand added to the existing brands such as JR, Futaba, Hitec, etc. Introduced in 2005 for model car racing, it is now offered for "park flyer" model airplanes. It may very well be the start of a revolution in model sailboat racing, too. Its features include:

1. Forty boats can sail at the same time in addition to those using the thirty-six channels at 75 and 27 MHz. (Actually there are 80 channels at 2.4 GHz, but the radio uses two channels for each boat for higher reliability.)
2. No channel crystals are required.
3. When the DX6 system is turned on it automatically searches for two clear channels.
4. Other R/C radios cannot cause interference.
5. The Tx uses a unique factory-set code to communicate only with its receiver (Rx). There are 4.2 billion different codes.
6. There is no intermodulation interference, including the "23-channel syndrome."
7. Digital signal processing is used. No glitching.
8. Servo travel for both arm and drum sail servos is easily adjusted.
9. Dual rates and exponential rates can be selected for servo travel.
10. Control range is more than 1,000 feet. There is a convenient button on the back of the Tx to test radio performance before sailing.
11. Fail-safe programming will ease the sails if the radio signal is lost.
12. An owner can sail all his boats using one Tx by using a separate \$60 Rx in each boat. Each additional Rx is easily programmed to recognize only its owner's Tx.
13. Cost of \$199.95 includes the Tx, one Rx, four sub-micro servos, a 600 mAh NiCd Tx battery pack and an overnight charger that will charge the Tx and boat batteries.
14. The Tx is a 6-channel programmable computer radio with memory for ten models.
15. The small 6-channel Rx weighs 7 grams and uses only 75 mA.
16. The Tx antenna length is only about ~6 inches. The top 3-1/2 inches can be swiveled 90 degrees to present the correct orientation to the boat.



*Spektrum DX6. Like many home telephone systems, the DX6 transmits on the 2.4GHz band. The system features DualLink™ (pat pend) technology that actually transmits and receives on two frequencies simultaneously, offering multi-path security.*

This new technology promises to improve, even further, the RC model sailing experience.

## Transmitter Setup for Sailboats

The DX6 is designed for small airplane and helicopter "park flyers." Park flyers are small aircraft, usually electric powered, which are becoming popular world wide. The Spektrum will control six different servos. For boat racing, only two or three servos are typically used. It is also a "computer" radio, which will remember all the settings for up to ten different boat or plane models.

The owner's manual has 95 pages, but most of it is for helicopters and things we don't use such as flaps and retractable landing gear.

After you have checked out all the stuff in the box it is time to set up the transmitter (Tx). To use the radio takes a bit more setup time than the typical radio used for boats.

**Caution:** Always charge the DX6's Tx batteries using the charger that comes with the radio. The polarity of the DX6's Tx charge jack is different from most radios. The black wire is positive and connects to the outside of the jack. The negative red wire connects to the center of the jack.

*Getting the polarity wrong will damage the radio. Unfortunately the Tx charge connectors used by Futaba and Hitec will fit the DX6's jack!*

All DX6 programming uses the on/off switch and the two red buttons on the lower face of the Tx. The red buttons are normally centered and inactive. They are pushed up or down to use them. When released, they return to center.

When the Tx is turned on, the LCD screen displays battery voltage at the bottom and the selected model name at the top right. I named the setup for my two boats "BT1" and "BT2". Recall that ten models can be stored.

### Model Naming

1. With the Tx off, push up and hold both the red SCROLL and INCREASE buttons, and then turn on the Tx.
2. Push up the SCROLL button until MDL appears.
3. Push up the INCREASE button to show "1" (or any number 1-10).
4. Push up the SCROLL button. The first letter of the name will flash.
5. Push up the INCREASE button to choose the letter you want.
6. Press down the CHANNEL button to select the second character and repeat step

## Spektrum DX6 RC System

If you cannot find this radio at your local hobby shop, go to:  
[www.spektrumrc.com](http://www.spektrumrc.com)

Use *Store Locator*, or go to:  
[www.horizonhobby.com](http://www.horizonhobby.com)  
Horizon Hobby, Inc.

Attn: Spektrum  
4105 Fieldstone Road  
Champaign, IL 61822  
Main Phone: 217-352-1913  
Toll Free: 800-338-4639  
Phone Support: 877-504-0233  
Mon-Fri. 8am-7pm CST

5 above. Only the first two characters can be programmed. The third character (a numeral) is selected in step 3 above when selecting the model.

7. Exit by simultaneously pushing up both red buttons.

8. Turn off the Tx.

### Model Type Selection

The DX6 is designed for model aircraft and helicopters. There is no selection for boats, but the "Aircraft" mode works best for our application.

1. With the Tx off, push up and hold both the red SCROLL and INCREASE buttons, and then turn on the Tx.

2. Push up the SCROLL button until TYP appears.

3. Push up the increase button to show "AC" (airplane), not "HE" (helicopter).

4. Exit by simultaneously pushing up both red buttons.

5. Turn off the Tx.

### Wing Type Selection (For Boats)

This procedure sets the correct mode for model sailboats.

1. Push up and hold the red SCROLL and INCREASE buttons and then turn on the Tx.

2. Push up the SCROLL button until "MIX WING" or "MIX VTL" appears.

3. Push down the CHANNEL button until "MIX WNG" and "OF" appear on the screen.

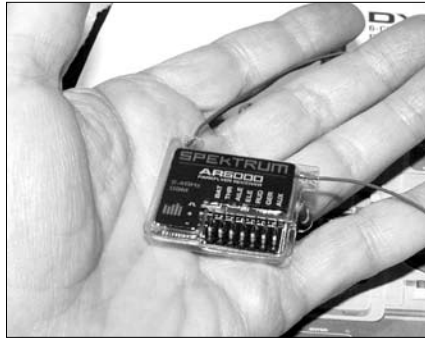
4. Exit by simultaneously pushing up both red buttons.

5. Turn off the Tx.

Now that the Tx is ready, it's time to set up the boat.

## Setting up the boat

The sail servo uses the Receiver's throttle (THR) connector. The rudder servo uses the aileron (AILE) connector. Plug the battery into the battery connector (BAT). Don't install the Rx in the boat until all programming is complete and tested.



*The DX6 Rx is Small. Each DX6 receiver is actually two receivers in one, hence the dual antennas. When turned on, the first receiver scans the 2.4GHz band until it finds the transmitter's code, which it has been programmed to recognize (called binding), and locks on that signal. Then the second receiver scans the 2.4GHz band, finds the second transmitted code that it has been programmed to recognize, and also locks on that signal. This whole process takes less than 5 seconds. The receiver is then locked to the transmitter via two independent channels, and is virtually immune to model-generated or outside interference.*

### Setting Rudder Servo Direction and Travel

1. Turn on the Tx and then the Rx (It will take about 5 seconds for the Tx to take control of the boat.)

2. Simultaneously push up SCROLL and INCREASE buttons.

3. Push up the SCROLL button to select REV-NORMAL.

4. Push down the CHANNEL button to select AIL. (Aileron is used for the rudder control on boats.)

5. Use the INCREASE button and move the rudder stick until the rudder moves in the correct direction.

6. Push up the SCROLL button to select TRV ADJ (travel adjustment).

7. Push down the CHANNEL button to select AIL

8. Move the rudder stick to the right limit of its motion. Use the INCREASE/DECREASE button to get the desired travel.

9. Repeat step 8 with the stick to the left.  
Turn off the Rx, then the Tx.

## Setting Sail Servo Parameters

Adjust sheets so that the servos will not be overloaded during travel adjustment. Both drum and arm servos are easily adjusted.

### Setting Servo Direction

1. Turn on the Tx, then the Rx.

2. Simultaneously push up SCROLL and INCREASE buttons.

3. Push up the SCROLL button to select REV-NORMAL.

4. Push down the CHANNEL button to select THR. (Throttle is used for sail control on boats.)

5. Use the INCREASE button until the sail servo arm (or drum) moves in the correct direction when the servo stick is moved.

Turn off the Rx, then the Tx.

### Setting Sail Servo Travel

**Caution:** *Because of the nature of digital trim there is a danger of overload or over travel of the sail servo. The procedure below for a CR 914 is used as an example. The same principles apply to other boats using arm or drum winches.*

### Setting Sail Servo Travel for a CR 914

1. Turn on the Tx, then the Rx.

2. Push down the sail trim lever until maximum travel is reached (+ or - 40).

3. Simultaneously push up SCROLL and INCREASE buttons.

4. Push up the SCROLL button to select TRV ADJ.

5. Push down the CHANNEL button to select THR.

6. Move the sail servo stick down to the limit of its motion. But, don't let the servo arm hit the keel tube.

7. Use the INCREASE/DECREASE button until there is about a 1/4 inch space between the servo arm and the keel tube when the sail servo stick is down until it stops.

8. Move the sail servo stick up until it stops.

9. Use the INCREASE/DECREASE button until the main boom is hits the shrouds.  
Turn off the Rx, then the Tx.

Test the system to assure all adjustments are correct.

## Sailing the Boat

### Selecting the Model to Sail

If you are using the DX6 to control more than one model, you must tell the Tx which boat you plan to sail. This is how to do it:

1. Push up and hold the red SCROLL and INCREASE buttons and then turn on the Tx.

2. Push up the SCROLL button until MDL appears.

3. Use the Increase/Decrease button until the number of the correct model appears.

4. Exit by pushing up both red buttons.

If you have several models, a cheat-sheet pasted on the bottom of the Tx may be useful.

### Radio Performance Check

Put the model on the ground and walk away from it 30 paces, or approximately 90 feet. Depress and hold the "BIND/RANGE TEST" button on the back of the Tx. Operate the sail and rudder servo. The rudder is easily

seen at that distance. At 90 feet, with the Range Test button activated, the boat should be in complete control. The radio check can also be done in the water. While holding down the test button, sail the boat away from you until control is lost. Orientation of the Tx antenna will effect the distance at which control is lost.

### Antenna Orientation

As with other radios, the strongest signal to the boat is when the antenna is vertical, or perpendicular to the line-of-site to the boat. The DX6 makes that really easy to do. The top portion of the Tx antenna can be adjusted through 90 degrees. If you tend to hold your radio in a horizontal position just move the antenna tip to a vertical position.

### Rudder Trim Is Digital

The rudder on most boats is not perfectly centered. The rudder trim lever allows you to center the rudder. But the DX6 trim is digital. When the rudder trim lever is pushed once, a small change occurs. If the lever is held against the stop, the trim will be much faster. Each time the trim is used, a negative or positive value appears briefly on the screen. If when you have properly trimmed the rudder, the screen shows -16, that setting can be used to set the trim each time the boat is used. (If this value is greater than 20-30 points, the owner should make a rudder linkage mechanical adjustment.)

See **Advanced Programming** to learn how to set the correct rudder trim to read "0."

## Advanced Programming

The DX6 offers options that may be useful to you, once you are comfortable with the radio.

### Fail-Safe Settings for Sailboats

If the radio signal is lost, the Rx automatically sets the sail servo in the position you

have chosen. Only the sail servo position can be set in fail-safe mode. Each owner has to decide what fail-safe sail setting is best for his boat and venue.

1. Turn off the Rx, then the Tx.
2. Insert the binding plug, which is in the radio package, into the Rx BAT port.
3. Sail and rudder servos should be inserted in the throttle and aileron ports.
4. Power the Rx using any unused port. An Rx LED should blink. (The manual says it's a blue light, but mine is amber.)
5. Turn on the Rx.
6. Position the sail servo stick in the desired fail-safe position. While holding down the binding button on the back of the Tx, turn on the Tx.
7. After approximately 5 seconds, the sail servo will go to the fail-safe position. Release the button.
8. Important: Remove the binding plug and make the correct Rx connections.

### Smooth Sail Servo Action

The sail servo stick has a ratchet-like feel. If you prefer a smooth feel, open the Tx back and reverse the ratchet spring strip on the gimbal. The case and ratchet screws can be tight so use care not to strip their Philips heads.

### "SUB TRIM" For Rudder Trim Reading

The Sub Trim function allows the owner to set the trim read-out on the LCD screen to "zero." When the rudder trim lever is used to center the rudder, there is a reading on the screen giving a +/- value for the trim. If this value is greater than 20-30 points, the owner should make a rudder linkage mechanical adjustment.

Example: Assume that the screen trim reading is -16 when the rudder is centered.

1. Simultaneously push up both SCROLL and INCREASE buttons.

2. Push up the SCROLL button to select "SB-TRIM".
3. Use the Increase/Decrease buttons to show -16 on the screen. (When the value -16 is used, it tells the radio how much correction to use to make the trim reading show as zero when using the radio.)
4. Push up the SCROLL button to select TRV-ADJ.
5. Simultaneously push up the SCROLL and INCREASE buttons to exit.

### "DUAL RATE" For Rudder Control

Dual Rate (D/R) is a feature that lets the skipper change rudder sensitivity by the simple use of a switch. We all know that each time the rudder is deflected, the boat is slowed by rudder drag. By choosing a less sensitive setting, there is less rudder motion.

The D/R switch is located at the upper right of the Tx face and labeled "AILERON D/R". The switch has two positions; "0" and "1." Position "0" is normally used for the higher, or more sensitive, rate. Set it up as follows:

1. With the Tx off, push up and hold both the red SCROLL and INCREASE buttons,



The AR6000 receiver comes with the DX6. Compared to the receivers most of us are used to, the AR6000 is tiny. Weighing in at 7 grams (1/4 oz), it's probably the lightest receiver made.

LOA - 46"  
BEAM - 9"  
HULL - FIBERGLASS  
MAST - 61"  
DISPLACEMENT - 16 LBS

### KIT \$349

INCLUDES: HULL, MYLAR  
SAILS, CAST LEAD INGOT.  
3-PIECE HOLLOW LAMI-  
NATED MAST, AND ALL  
HARDWARE

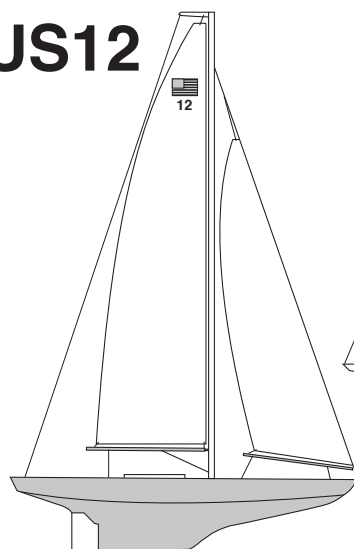
KIT WITHOUT SAILS, MAST,  
AND BOOMS \$275

KIT WITH WALRUS  
3-PANEL SAILS \$399

HULL ONLY \$125

US12 T-SHIRTS \$15

## US12



ALL PRICES PLUS  
SHIPPING AND HANDLING

## LIBERTY 34

LOA - 34"  
BEAM - 7-1/2"  
HULL - FIBERGLASS  
**NOT PLASTIC**  
MAST - 46"  
DISPLACEMENT - 8 LBS

### KIT \$299

HULL ONLY \$75

**CONTACT:**  
HERB HARRIS  
P.O. BOX 214792  
S. DAYTONA, FL 32121  
386-767-7614

**OR**  
DON HAWES AT:  
US12SAILBOATS.COM

and then turn on the Tx.

2. Push up the SCROLL button until “D/R SW” appears.
3. Push up the INCREASE button to select “E.A.”
4. Push up SCROLL to select “MIX WNG.”
5. Push up the SCROLL and INCREASE buttons to exit. Turn off the Tx.

The above sets the Tx to use the “AILERON D/R” switch for the rudder.

1. Turn on the Tx.
2. Simultaneously push up both SCROLL and INCREASE buttons
3. Push up the SCROLL button until “D/R” and “A I 0” shows on the upper screen. The “A I” stands for aileron (used for rudder on boats). The “0” indicates switch position “0.” “100%” is displayed at the bottom of the LED screen. This means that in switch position “0,” rudder stick movement will move the rudder 100% of the original rudder travel chosen in “Setting up the boat.”
4. Move the “AILERON D/R” switch down to position “1.” Screen will show “A I 1” in upper right.
5. Push down the decrease button to select 50%. (or any value you choose).
6. Simultaneously push up both SCROLL and INCREASE buttons to exit.

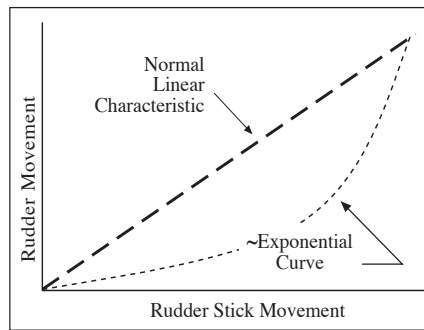
The above sets 50% for rudder travel when the switch is in position “1.” Experiment to find the percent setting that works for your boat.

#### “EXPONENTIAL RATE” Rudder Control

Exponential rate offers some of the benefits of dual rate at one switch setting. As the rudder stick is moved from the neutral position, rudder sensitivity is low. That is, for large stick movements the rudder movement is small. As the rudder stick is moved further, the rudder deflects at increasing rates until at full stick deflection full rudder deflection is achieved. This characteristic minimizes rudder movements (maximizes boat speed) in straight line sailing, but still gives large rudder deflections when strong maneuvering is required. (A problem with linear “Dual Rate” is that a skipper may forget to move the D/R switch to the position he wants.)

Before setting exponential rudder set both “0” and “1” rudder switch positions to 100% travel as follows:

1. Turn on the Tx.
2. Simultaneously push up both SCROLL and INCREASE buttons.
3. Move the AILERON “D/R” switch up to position “0.”
4. Push up the SCROLL button until “D/R” and “A I 0” shows on the upper screen.
5. Move the “AILERON D/R” switch up to position “0.” Screen will show “A I 0” in



*Exponential rate adjustment is a function that allows you to tailor the response rate of the controls when compared to the stick inputs. The adjustable range of the DX6's exponential rate function is from 0–100%. Zero percent (0%) means the response rate is constant throughout stick movement. One hundred percent (100%) is the highest exponential rate that is available. The higher the exponential rate value, the less servo action, or sensitivity, you will notice around the neutral setting.*

- upper right.
6. Use the Increase/Decrease buttons to set 100%.
7. Move the “AILERON D/R” switch down to position “1.” Screen will show “A I 1” in upper right.
8. Use the Increase/Decrease buttons to set 100%.
9. Simultaneously push up both SCROLL and INCREASE buttons to exit.
10. Turn off the Tx.

Set exponential rudder as follows:

1. Turn on the Tx.
2. Simultaneously push up both SCROLL and INCREASE buttons.
3. Push up the SCROLL button until “EXP” appears at left of the screen.
4. Push down the CHANNEL button until “A I 0” or “A I 0” appears on the screen.
5. Move the “AILERON D/R” switch up to position “0.” Screen will show “A I 0” in upper right.
6. Push down the decrease button to select 0%. (This sets the rudder for linear characteristic (not exponential) when the “0” switch position is selected.)
7. Move the “AILERON D/R” switch down to position “1.” Screen will show “A I 1” in upper right.
8. Push up the increase button to select 100%. (One hundred percent (100%) is full exponential. You will have to experiment at the pond to find the rate that works best for your boat.)
9. Push up the SCROLL button until SBTRIM appears high in upper left of the screen.
10. Simultaneously push up both SCROLL

and INCREASE buttons to exit.

11. Turn off the Tx.

That does it. Using “Aileron D/R” position “0” gives full travel with a linear characteristic. Using switch position “1” gives full travel but with exponential rudder characteristic.

Test the settings with the boat turned on.

Enjoy your DX6!

## Anecdotal Reports on Radio Range of the Spektrum DX6 are Incorrect

by Chuck Winder

Some in the model sailing community seems concerned that the DX6 does not have sufficient range for model sailboats. A possible reason is that the earlier DX2 version did occasionally have a range problem. My CR 914 has a range significantly longer than 500 feet with the standard Dual DX6 Rx inside the boat. Rob Guyatt, RMG Sailwinch (www.rmgsw.com), in Australia writes:

“I have used the DX6 only once but from that I suspect that the range is not a problem. What I did was just stuff the Rx and the two antennas into the radio pot in my Disco IOM. I mean literally stuffed in because the two antennas were just scrunched up in the pot so that I saw worst case scenario performance. A very quick range test showed a distance of about 150 m (nearly 500 ft) on the water before loss of control. That's plenty. I've heard guys say that they get 1000 ft when they stretch the antennas out according to the instructions. I never experienced the range problems with the original modular Spektrum system that others reported... I always got more than enough range for typical racing situations with the std antenna fully enclosed inside the pot of the Disco.

“There is one point that I think some skippers may have trouble with. If you hear of any skippers not getting the range that they would like then ask them if they are pointing the tx antenna at the boat. It is very important to bend the tx antenna upright. Try this yourself. Point the tx antenna straight at the boat and see how much less range you get. I suspect that in some cases it was incorrect tx antenna orientation that was giving grief to skippers with the original system. They may well have not needed the rx extension.”

# Modifying a Spektrum DX6 Transmitter

or

## Voiding Your Warranty with One Tiny Solder Joint

From Issue 149

by Jim Linville

There's no doubt in my mind that the Spektrum DX6, six-channel 2.4 GHz RC System (See figure 1.), has a lot to offer model yachters; just check out some of its features: (1) there are no crystals to swap out; when you start up a DX6, it searches for, selects, and locks onto two clear channels, and it has 80 new channels to choose from; (2) no glitching; in fact, the 2.4 GHz frequency is high enough that it won't be bothered by electrical noise from dirty servos and other such critters; (3) it has a 10-model memory, so you can program and save set-up points for 10 different models; (4) it's digital trimmers have better resolution than analog trimmers; (5) the 2.4 GHz receiver is tiny, weighing only 7 grams (1/4 ounce); and (6) the antennas are so short they don't get in the way.

The only drawback I can find is that the DX6 is designed for electric aircraft (Park Fliers). While it's perfectly legal to use a 2.4 GHz system in the model yachting world, the DX6 comes with a standard North American joy stick arrangement, that is, two functions (throttle and rudder) on the left joy stick, and two functions (aileron and elevator) on the right. Two different functions can be controlled by simple on and off switches on the top of the transmitter. The AR6000 Spektrum receiver is also optimized for park flyers, and its channel labels relate to aircraft instead of model yachts. As a cross-reference, THR controls the

sheets; AILE controls the rudder. We're modifying ELE and RUD so they can be controlled independently of the transmitter's joy stick, and GER and AUX are controlled by the two switches on top of the transmitter. BAT is where you plug in the battery circuit. (See Figure 2.)

with one new pot and an adjustable backstay servo with the other. For what it's worth, you could also control a jib twitcher with one of the on/off switches.

If you can solder, you can modify a DX6. It's really pretty easy. All you're doing is replacing unused potentiometers (pots) in the DX6's joy sticks with pots of the same electrical values, which you mount on the transmitter case where you can control them more conveniently. Just be careful not to short out circuit board "legs" with molten solder. And remember that your warranty will be void the second you snip the first potentiometer terminal.

I use 16 mm (5/8 in.) diameter, 5K Ohm, linear taper potentiometers, which I purchase from a local electronics supply house (Philmore PC73s). The larger 5K pots available at Radio Shack will fit if you're careful.

So here's how I do it.

1. Remove battery case cover.
2. Unplug and remove the battery. The Spektrum battery plug is often hard to remove, and sometimes you need to use long nose pliers to gently rock the plug back and forth while pulling. These plugs are different from the plugs most of us are used to. They're also used on cell phones, and I've been able to get extras by clipping them from bad cell phone batteries, which my friends save for me. Other skippers have told me that they can get all of the bad cell phone batteries they need by asking for them at Radio Shack.
3. Remove six case screws.
4. Remove the back and locate auxiliary pot PC board One.



Figure 1. An unmodified Spektrum DX6 transmitter.

If you control only the two normal functions on your model yacht (sail and rudder), you can use the DX6 as is. The up-and-down joy stick function on the left side (which has built-in "clicker" stops) is used to control the sail servo, while the left-to-right joy stick function on the right side is used to control the rudder. If, however, you want to control more than those two normal functions, you will need to "multi-function" with the existing joy sticks, or modify them so the non-standard functions can be controlled with new potentiometers (pots) you add to the transmitter. For example, you can control a jib trimmer servo

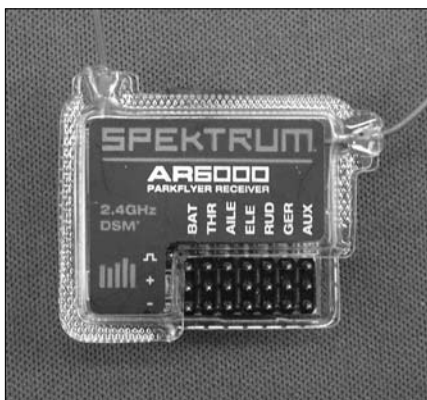


Figure 2. The Spektrum AR6000 receiver. For model yachting purposes, THR controls the sheets; AILE controls the rudder.



Figure 3. Removing the transmitter battery pack. Try pulling it out without the pliers first.



Figure 4. Locations of the six screws that hold the transmitter back in place.

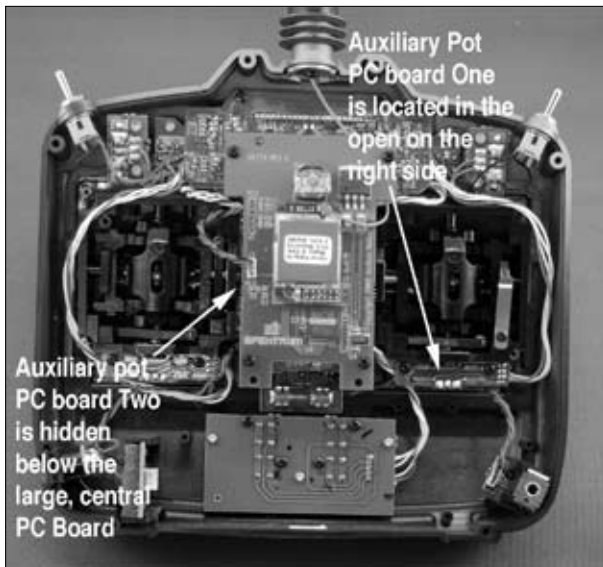


Figure 5. The Pots we want to replace are soldered directly to PC Boards that are mounted with screws to plastic studs.

5. Remove the two screws that hold auxiliary pot PC board One in place and tilt it towards the bottom of the transmitter.

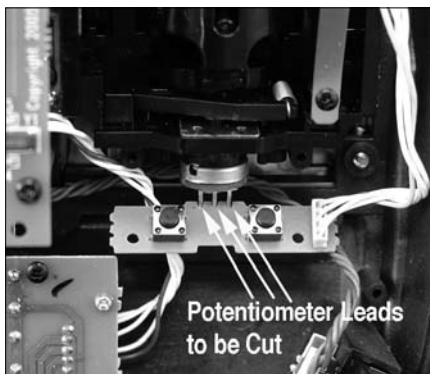


Figure 6. Auxiliary pot one with its leads exposed.

6. Using very small diagonal cutters, reach in and clip the leads of the potentiometer as close to the body of the pot as you can. The pot stays in place to act as a shaft and bushing for the joy stick. It doesn't hurt to paint the remaining stubs with fingernail polish or liquid electrical tape.



Figure 7. Clipping the potentiometer's leads. This is the point of no return. Do this and you void your warranty.

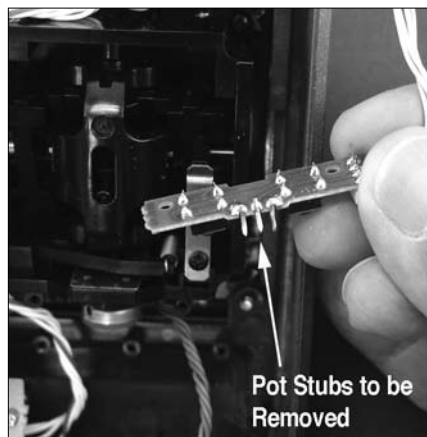


Figure 8. Be careful not to drip molten solder into the transmitter case.



Figure 9. This is what the PC board should look like before you reinstall it in the case. Make certain that the gaps between the pads have not been violated by solder.

11 (cont) three-wire servo lead. Solder one end to the new potentiometer and the other end to the three terminals on the PC board. The center lead on the PC board MUST connect to the center terminal of the new pot. IMPORTANT: Be careful NOT to bridge the

7. Once the PC board is free, move it to the side of the case. Desolder and remove the stubs of the clipped potentiometer leads. 8. Reinstall the PC board with the two screws you removed in step 5.

9. Locate and drill a new hole in the case for the new potentiometer.

10. Fit the new potentiometer in the hole and measure the distance from the new pot to the location of the PC board. Allow one inch extra and cut a piece of servo lead (three wires) to length.

11. Strip and tin both ends of a short piece of

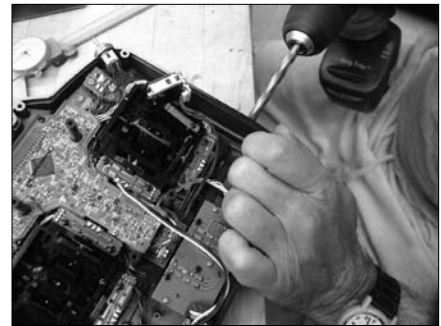


Figure 10. Be careful when drilling, the drill bit tends to grab.



Figure 11. This is what the new auxiliary pot one installation should look like when you're done. It's really pretty simple.

small gaps between the three terminals with molten solder.

That's all there is to it. It sounds complicated, but it's not. If you only want to modify one channel, you're done.

If you want to modify a second channel, simply remove the four screws holding the large central PC board in place, lift it out of the way, and follow steps 5 through 11 for Auxiliary Pot Two.

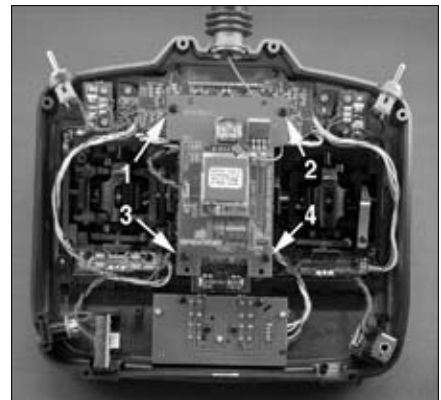


Figure 12. For auxiliary pot two, you simply remove the four screws holding the central PC board in place, lift the board out of your way, and repeat steps 5 through 11.

12. When you're satisfied with your work, re-assemble the transmitter.

- a. Re-install the large central PC board (four screws).
- b. Re-install the case back (six screws).
- c. Plug in the battery (remember to ob-

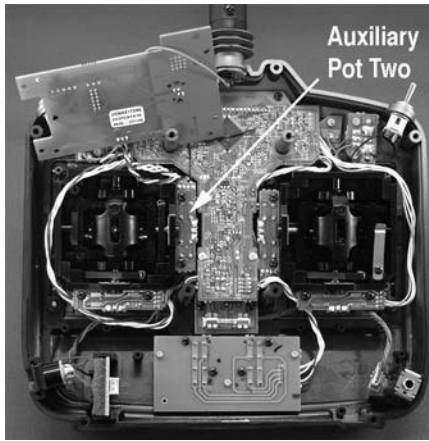


Figure 13. The PC board for auxiliary pot two is easy to access with the central PC board laid to one side.



Figure 14. This is auxiliary pot two... ready for clipping. Don't worry, you've already voided your warranty.



Figure 15. This is what the finished assembly looks like on my transmitter.

serve the polarities marked on the

battery jack PC board—positive to-

wards the bottom of the transmitter).  
d. Replace the battery case cover.

13. Turn on the switch and bind the receiver per the directions in the Instruction Book.

## Spektrum DX6 Lessons Learned

by Chuck Winder

**T**hese are some observations after having used the radio since April 2006:

**Range.** Radio range of the DX6 has been demonstrated to be more than adequate for racing sailboats. Receiver (Rx) antenna orientation does not seem to be very critical.

**Transmitter (Tx) Battery Life.** Battery life will be about 2-1/2 hours using the stock Spektrum 600 mAh pack. The Tx alarm sounds at 9 volts, but the boat will remain in control at well below 8 volts, as shown on the Tx LCD screen. I have had full boat control down to 7.0 volts. There may be a second battery alarm in the vicinity of 7 volts. A 2,500 mAh pack will give ~10 hours life.

**Tx Rain Protection.** The Tx will stop working if not protected from rain. A plastic bag will work if it's large enough to get your

hands inside.

**Rx water protection.** The Spektrum Rx requires protection from water incursion. Its appearance suggests it might be waterproof or at least water-resistant compared to other conventional radios. But it will not withstand full water immersion. An Rx in a boat that almost sank was immersed in saltwater, stopped working, and could not be recovered by cleaning and drying. A coating of Vaseline might be effective.

**Spektrum will "orbit" the boat with Tx off.** It is often convenient to turn off the Tx with the rudder offset for a turn. The boat will orbit in place, so a skipper can attend to other things. The fail-safe setting of the sail servo should be set partially eased, to encourage stable orbiting.

**The Tx antenna hinge is fragile.** An antenna hinge broke and went unnoticed because

the impact was so minor. The Tx must be returned to Spektrum for replacement. Temporary repair using tape will protect the antenna wire that is routed through the hinge.

**Exponential steering may improve racing performance.** I like exponential steering. It lets me steer more smoothly on all points of sail, which should mean that boat speed is better. I use 40 and 70 percent exponential settings for switch positions "0" and "1" respectively. So far the 70 percent setting has worked well for me. The switch can be accidentally moved during sailing. Originally, a linear setting was used for switch position "0", but when "0" was accidentally selected, my steering became quite erratic.

In summary, the Spektrum DX6 is an excellent product. No glitching and 40 new channels with no need for crystals are great features.



**NEW DX6i**

### Spektrum's New DX6i 2.4GHz DSM2 Is Here!

see website from more details on all these new products

- Improved longer lasting batteries included no need to upgrade
- Improved charger output increased to 150 Mah
- Compatible with any DSM and DMS2 receivers
- Countdown / Count up timer—helpful to hear AMYA starts
- \$179.99

**Windjammin Sails**  
[www.beanbag.com/wjsails.htm](http://www.beanbag.com/wjsails.htm)  
 (937) 291-1163



**Now Available**  
**Deluxe Transmitter Case**  
*Foam pre cut for custom fit*  
**\$59.99**



**\$69.99**

The unique *Raydiowarm* design helps keep hands and transmitter warm and dry ~ even in the worst weather.





# Soling One Meter Construction Tips

From Issue 148

by John Pitkin

**T**he Soling One Meter, or SIM, has been around for many years. It has proven to be a good sailing model yacht at a reasonable cost. However, the parts as supplied in the kit are not as accurate as CNC machined, roto-molded, or laser cut parts that have become common in newer kits. That doesn't mean the kit has problems. It just means the builder needs to do a little preparation before joining the parts.

The hull, in particular, needs trimming to match the bulkheads. The hull parts are vacuum formed styrene plastic. After forming, excess plastic is cut away, leaving a part with rough cut edges. The edges must be trimmed and sanded or the bulkheads and transom will not fit correctly. Unfortunately, there is no mention of this in the kit-supplied instructions.

There is good news. A little attention to fitting the parts allows the boat to go together with ease. The areas needing detail work are the hull sides, the keel shell, and the keel trunk.

These building tips are not intended to replace the instruction manual supplied with the kit. Use these tips as supplemental information and an aid to construction. Dry fit all the pieces before gluing anything. Hold pieces in place with tape or clothespins while you check alignment.

## A Word on Jigs

While some builders may disagree, I don't believe that it is necessary to use a fancy jig to assemble a Soling One Meter. Building an accurate jig can require more skill and better tools to achieve results that may not be any better than can be achieved with a simple stand and careful attention to detail. These tips present an alternative method to the jig-aided assembly, covered elsewhere in this issue, though most of the techniques apply to either method.

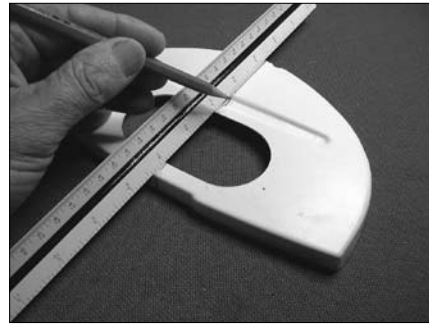
## Centerlines for Accuracy

The first step is to draw centerlines on the inside of the deck and hull, and vertical centerlines on the bulkheads and transom. These lines are critical for alignment. Using them eliminates any need for a building jig. Use pencil for making marks. Magic markers or ink pens will bleed through the plastic, or will spoil a paint job.

To find centerlines on the bulkheads, make a tracing of each bulkhead on paper; cut out the tracing and fold it in half vertically.

Open the fold and set the tracing on the bulkhead. Mark a centerline at the crease.

To draw a centerline inside the hull, use a flexible straightedge. Draw from the center of the keel slot through the rudder post hole, extending the line aft to the transom and about 1 inch forward of the keel slot. The line will be slightly curved. Flip the straightedge to the other side of center and draw it again. The two lines will vary less than 1/8 inch. Average the two lines to identify the center of the boat.



*Drawing centerlines is a must for accuracy.*

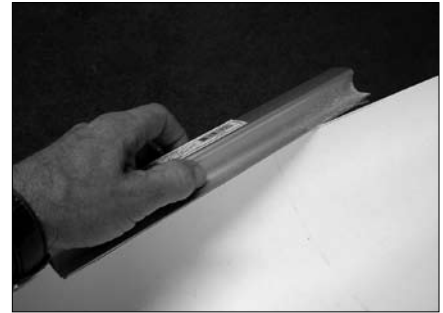
## Match the Hull Sides to Bulkheads and Transom

As supplied from the factory, the hull sides are likely to be too high. That is a good thing. It gives you something to trim for a tight fit. If the hull sides were too low, it would require cutting down the bulkheads.

After locating the bulkhead positions per the plans, press the forward bulkhead down into the hull and align the centerlines. Scribe a line along the bulkhead flange. Do not glue in the bulkhead yet! Check the hull height at the corners of the bulkheads. The hull edge should be about 1/16 inch below the top edge of the bulkhead. A slightly proud bulkhead allows room for the curve of the deck flange. Use a sanding block or bar to remove material from the top edges of the hull until you have nicely faired lines from bow to stern passing 1/16 inch below the tops of the bulkheads.



*This forward bulkhead is pressed into the hull with the centerlines aligned. The hull edge is above the bulkhead and must be trimmed or sanded to fit.*



*A sanding bar with 100 grit sandpaper is used to adjust hull height and smooth the edge. Use tape, or scribe a line, to indicate how much to take off the hull.*

The hull from the kit used in this article was 1/8 inch too high at the forward bulkheads and the starboard transom. The port transom area was high by 1/16 inch. It was about the same on three other SIM hulls I've built. That 1/8 inch may not sound like a lot; but it's the difference between having a poorly fitted deck that may put a permanent twist in the boat, thus allowing it to flex, or a firmly fitted deck and rigid hull that transfer all the power of the sail to movement through the water.



*This is what the deck-to-bulkhead joint looks like before the hull is trimmed. The deck is unsupported and will not have a good bond with the bulkhead.*



*This hull is trimmed and the bulkhead joint is tight.*

## Fitting the Transom

Locating the transom presents a special problem. Measuring from the bow may be inaccurate, and measuring from the other bulkheads may compound any errors. It is best to find the correct transom position by using the deck as a guide. The transom and hull must fit

inside the deck flanges. Place temporary 1/16 inch spacers inside the deck flanges in the approximate transom position. The spacers allow clearance for the hull. Next, place the transom inside the deck with the flange facing forward, and push it as far to the rear as it will go. Here, it may be helpful to measure from the bow to each side of the transom where it meets the deck. This can be done accurately by taping a string to the center of the bow and using it to make the measurements, being careful not to stretch it when making measurements.

When you are satisfied with the location, mark the location of the transom inside the deck, and transfer the position to the outside of the deck flange.



*Transferring the transom location to the outside of the deck flange. Editor: The illegible note on the left reads: Temporary 1/16 inch Balsa spacers allow for hull thickness.*

Remove the spacers and temporarily tape the deck on the hull. Be sure the deck is pushed onto the hull as far aft as it will go. Transfer the marks you just made on the deck flange to the hull. This is the correct position for the top of the transom. With the deck still on the hull, turn the boat upside down and put the bow against a wall. Measure back one meter, or 39-3/8 inches. Per the control drawing, the bottom of the transom must be at the one meter mark.



*Measuring boat length with bow and tape against a wall.*

Transfer the maximum length mark to the inside of the hull. You can hold the boat up to the light to see the mark through the hull.

With the hull sides trimmed, the bulk-

heads and transom will install straight and true. Just line them up with your centerline markings and scribed lines. When you finish installing equipment and fittings inside the hull, the deck will fit properly and solidly against the bulkheads.



*Here the hull is trimmed to match the transom. Transom is held temporarily with tape. A line is scribed along the transom flange to use for alignment. A hull reference mark is on the right side where the deck flange markings were transferred.*

#### A few reminders

Before installing bulkheads, make sure you cut any limber holes for drainage.

Cut a slot in the forward bulkhead flange wide enough for the keel trunk, plus room for any drainage holes.

Do not cut off the rear of the hull or the deck until after joining the deck to the hull.

Assemble things with tape as a dry fit before gluing anything.

When gluing in the bulkheads, it helps to use some small clamps. Metal clamps are heavy and may crack the plastic hull if bumped. Make some small clamps from wooden clothespins. Simply sanding the tips will give you some handy shapes.

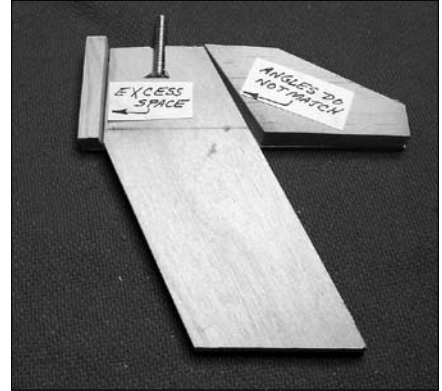


*Customized clothes pins make great modeling clamps. Pins on the left have angled jaws. Pins on the right have curved jaws. They were shaped on a disc sander in just a few seconds each.*

#### Fitting the Keel and Trunk

The S1M keel trunk is designed so that just about any factory-made keel will fit with a little filing or sanding. The trunk has a lot of clearance built into the pieces. Keels with varying spar angles will fit, albeit, not securely. The angle of the trunk filler block does not match

the keel spar. The oversized keel slot may allow the keel to rock fore and aft. Setting the boat down on the keel, or running aground, puts excessive pressure on the hull via the trailing edge of the keel and may lead to hull fractures. To reduce the chance of hull damage, parts of the keel trunk should be fitted closely to the keel spar. This builder likes the trunk to support the keel in all directions.

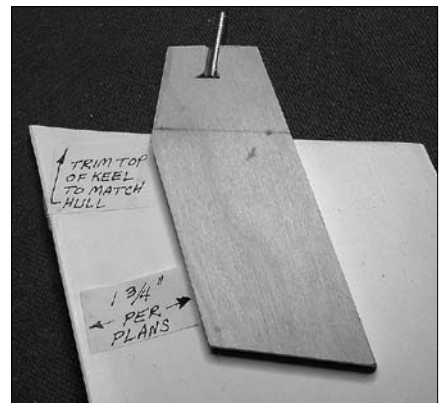


*Factory-cut keel trunk pieces do not fit closely to the keel spar.*

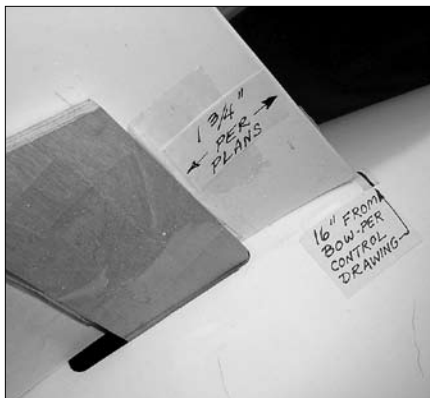


*Here, the keel trunk parts are fitted for better support, fore and aft.*

The plastic keel shell halves need attention too. The top angle should line up with the 1-1/2 inch spar extension.



*Place the keel spar on the keel per the plans at 1-3/4 inch from the leading edge and with 1-1/2 inch protruding from the top. This keel shell needs the flashing trimmed at the forward top section. It is too tall in the front by over 1/4 inch. The top line of the keel will be fitted to the curve of the hull.*



*The keel slot is cut too far aft on this hull. The leading edge of the keel barely comes within the Control Drawing dimensions at 16 inches, even with the keel pushed all the way forward in the slot. This keel slot needs to be extended forward. The rear of the slot will be filled in later. The keel shell in this photo is now fitted to the hull curve.*

Once you have the keel parts fitted, install the forward bulkhead. The kit instructions have you attach the keel trunk first; then install the bulkhead. This builder feels it is better to install both bulkheads and the transom before installing the keel trunk. This will ensure the boat is straight. Then, when you install the keel trunk, you will have a fairly solid hull to hold everything in place.



*This crude, but effective, stand was made from a cardboard box in less than five minutes and works fine for aligning the keel. Slots cut in the sides, front, and rear, provide sightlines and access. The boat is leveled left and right (fore and aft does not matter). Strings with weights hung from bow and stern are used to align the keel. Align the keel with suspended strings both vertically and longitudinally. The trailing edge of keel should line up with rudder hole and string. Later, the rudder is aligned vertically to the keel.*

### Complete the Interior

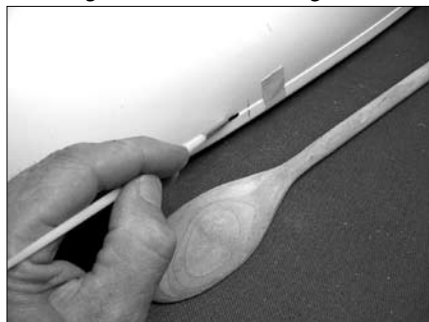
Do not attach the deck until you are sure you have completed all interior installations. If you are new to the SIM, check out how other builders have equipped their boats. Consider using through-bolted stainless hardware instead of the kit-supplied screw eyes. Plan all

hardware locations and interior reinforcement you may wish to add. If you decide to install racks or multiple locations for shrouds and jib tack fittings, do it before the deck is attached. As always, check to be sure that you are in compliance with the Class Rules and Control Drawings before making any modifications to the kit-supplied items or dimensions. A lazarette may be installed before, or after, attaching the deck.

### Attaching the Deck

Install the deck on the completed hull. Do not trim the deck or hull at the transom until after the deck is glued. Tape the deck to the hull at several locations around the hull-to-deck joint. Look inside the hull with a mirror to check that the deck sits firmly on the bulkheads. Now is your last chance to make any adjustments. As for adhesives, there are many choices. Slow set epoxies, plastic cements, MEK, and super glues to name a few.

This builder prefers to use MEK for solvent-welding the deck to the hull. It is applied sparingly with a small artist's paintbrush on the outside of the hull-to-deck joint. Use a paintbrush with natural bristles, as MEK may melt synthetic bristles. The MEK will wick under the deck flange and bond the deck flange to the hull.



*Deck is taped in position. A paintbrush is used to wick MEK into the joint.*

In order to obtain a solid fit, you'll need to push the hull outward against the flange. Use a wooden spoon handle to add pressure in the hard-to-reach areas.



*A wooden spoon is handy for reaching into the hull.*

The deck flange does not fit flush to the hull near the bow. For a better water seal and a smoother look, flatten the flange with heat from a model aircraft covering iron. (A household iron will work if you use a cloth to keep the iron from sticking to the plastic.)



*A model aircraft trim iron softens and smooths the hull plastic at the bow. A little marine filler will smooth any wrinkles.*

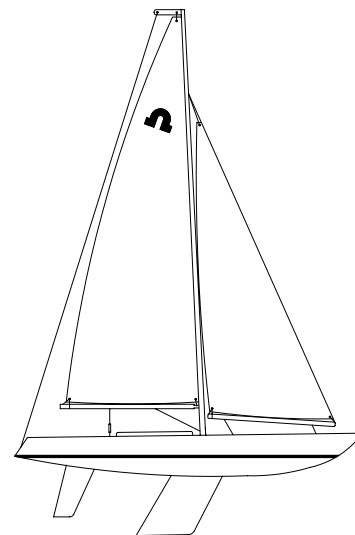
When the deck flange is sealed all the way around, reach inside the hatch opening and bond the tops of the bulkheads to the deck using MEK.

After the deck is installed, trim the deck and hull at the transom. Use a marine-type body filler for smoothing the transom joint.

### Summary

If the builder takes the time to fit the pieces, the Soling One Meter will go together easily and accurately. Plan ahead before permanently attaching the deck. Dry fitting the assembly with tape will help avoid major disasters.

Enjoy building your boat and be sure to visit the Soling One Meter Class website at <[www.solingonemeter.org](http://www.solingonemeter.org)> for additional information and a link to the Yahoo! discussion group, where you can ask questions and get answers as you are building your boat.



# A Drum Winch for Your Soling One Meter?

From Issue 148

by Jim Linville

I first saw this type of drum sheeting arrangement on a US One Meter. It was installed on deck with everything out in the open where it could be easily repaired. While I'd love to use an on-deck system for my Soling One Meter (SIM), I have come to the conclusion that the on-deck system is not suitable for the SIM. It would require too many line bypasses to clear the hatch cover. Therefore, my SIM drum sheeting system is installed inside the hull. I adapted it from the sheeting system used in my EC12s. Details for the EC12 are available on the EC12 Building site <[www.ec12.info](http://www.ec12.info)>.

In my opinion, drum winches are superior to arm winches for controlling an R/C boat's sails. They're more powerful than most arm winches, they save a little bit of weight (as much as 3-4 ounces), and that weight can be transferred to the keel where you need it. I believe that their speed is optimal for skippers with heavy thumbs (like me) ... not too fast, not too slow. I use the Futaba 5801 almost exclusively. I know there are other drum winches that are more powerful and a whole lot less expensive. But in my opinion, they're too slow, they weigh too much, and believe it or not, I think they're too powerful. My 5801 more closely duplicates the speed of a finely tuned racing crew when they round a mark and sheet in to head to weather. The sails are properly trimmed at every point of sail, and the boat gains speed through the whole maneuver instead of stalling when the sails are "snapped" into position.

Schematically, this drum winch system is pretty simple. (See Diagrams 1 and 2 and Photo A).

The Dead-end Ring is a PeKaBe thim-

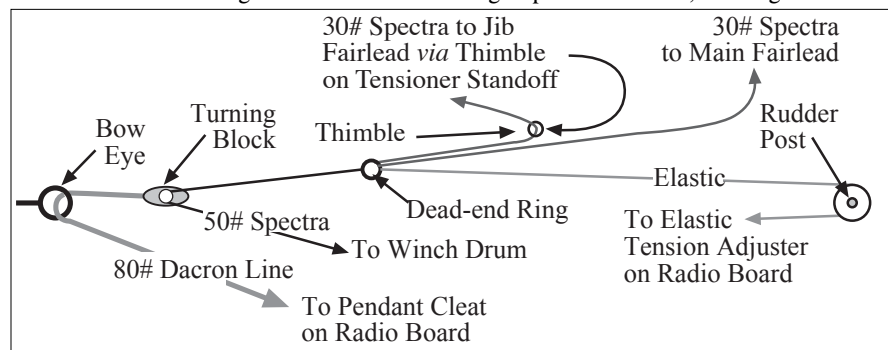


Diagram 1. Schematic drawing of the simple drum winch sheeting system.

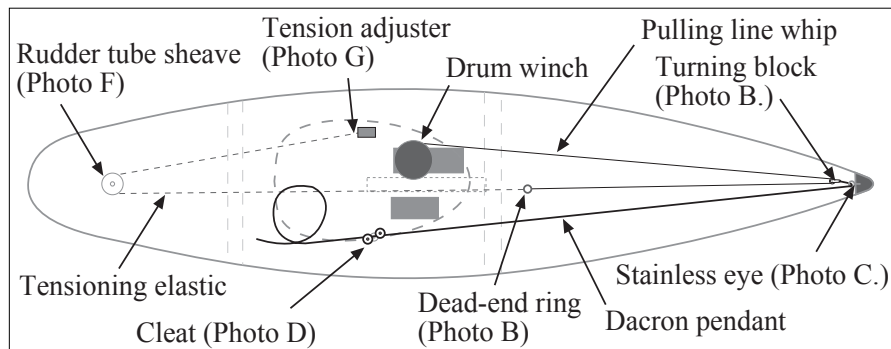


Diagram 2. Layout drawing of the drum winch sheeting system with labels calling out the related photos. Enough Pendant Line is stored in the bilge of the boat so the Turning Block can be pulled to the open hatch area for repairs. The coiled line is anchored in place with a spot or two of silicone sealant until it's needed.

ble, but it could just as easily be a split ring (or any other metal ring). There are four lines tied to the Dead-end Ring, (1) the Jib Sheet, (2) the Main Sheet, (3) the Tensioning Elastic, and (4) the Pulling Line Whip. The Jib Sheet runs from the Dead-end Ring, through the thimble on the Tensioner Standoff and back to the Jib Fairlead. The Main Sheet runs from the Dead-end Ring directly to the Main Fairlead. The Tensioning Elastic runs from the Dead-end Ring through the Tensioner Standoff, around the rudder post, back to the radio board where it terminates at the Elastic Tension Adjuster (Photo G). The Pulling Line Whip runs from the Dead-end Ring to the Turning Block in the boat's bow and back to the winch drum. The Tensioning Elastic is set so there is a slight pressure on the Pulling Line Whip when the sails are sheeted all the way out (including trim).

The Pulling Line Whip is adjusted so that the Dead-end Ring almost hits the Turning Block when the drum is fully sheeted in and stops just short of the Tensioner Standoff when the drum is fully sheeted out. Sheet-

ing in pulls the sails in; sheeting out lets the

sail out. As usual, the devil is in the details. The Emergency Line is installed in case the heavy Dacron Pendant Line or the Turning Block breaks, which is very unlikely. It is used to feed a larger replacement line to the bow where only a baby's hand will fit. (If you ever need to run a new line through the eye, remember to pull a new Emergency Line with it.) The Emergency Line is simply a loop of smallish string positioned out of the way, led aft on both sides of the hull, and bonded in place with silicone sealant (be sure to use sealant, NOT silicone adhesive). Sealant will break away when the line is pulled hard.

I like to keep as much weight as far forward as possible. Therefore, my radio board is mounted on top of the keel trunk, with the servos in cutouts beside the trunk. The receiver (a 7 gram Horizon Spektrum AR6000) is mounted beneath the deck with Velcro. I usually mount the batteries with Velcro under the deck next to the receiver. I know that doing this puts 3-4 ounces of dead weight higher in the hull than necessary, but electronics mounted under the deck are located as far from water in the bilge as possible. My mentor, Manny Costa, always said "You can't win a race you don't finish," and I've found that I have a lot of trouble finishing races with a wet receiver and battery pack. Sometimes I mount the batteries in a foam box located in front of the forward bulkhead. I carve this battery box out of pink insulation foam. The pink foam doesn't weigh much, but it keeps the batteries dry, and the weight is forward where it's often needed to balance the boat.

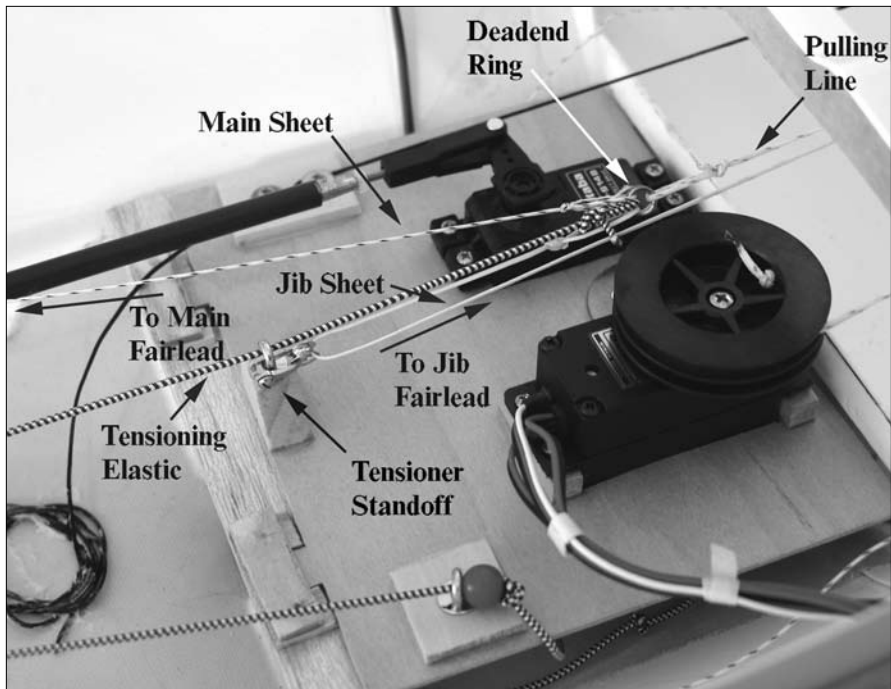


Photo A. The sheeting set-up looks a lot more complex than it is. For an explanation, refer to Diagrams 1 and 2 as you follow along in the text.

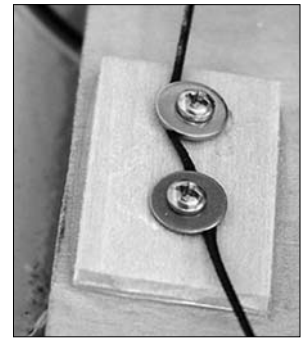


Photo D. The cleat for the Turning Block Pendant Line. The Pendant Cleat is made from two flat washers and two sheet metal screws. The Pendant Line is wrapped around the two screws beneath the washers in a figure eight and the screws tightened. Leave enough extra Pendant Line coiled in the bilge so the Turning Block can be pulled back to the open hatch cover area when the Spectra Pulling Line Whip needs to be replaced (or other repairs need to be made).

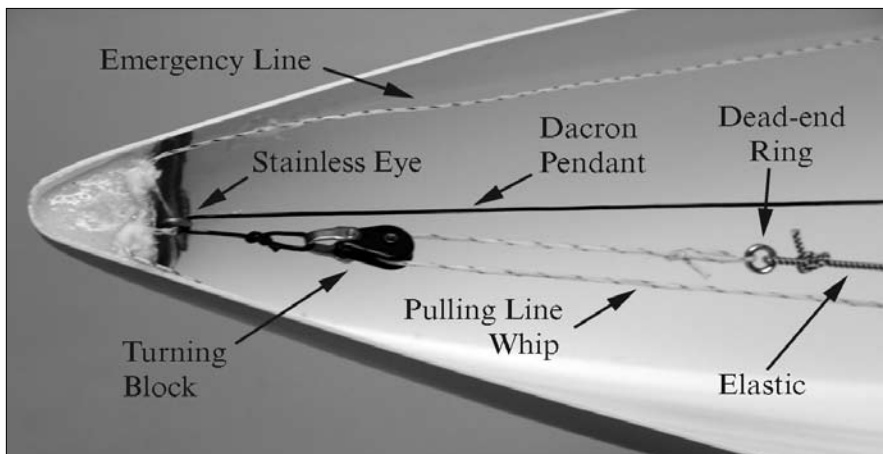


Photo B. The Turning Block installation. There's a lot to show in this photo, so please bear with me. The Turning Block is tied to an 80 pound test Dacron Pendant Line with a bowline knot, set with a drop of CA glue. The Pendant Line is then run through a homemade stainless steel eye securely attached in the bow with WEST SYSTEM epoxy (Photo C left and right). The Pendant Line runs aft from the Bow Eye to a cleat on the radio board (Photo D). An Emergency Line is also run through the Bow Eye and back along the sides of the hull. The Dead-end Ring is where the sheets (not shown), Pulling Line, and Elastic Tension Adjuster merge together. I use a PeKaBe thimble ring because it is designed to reduce chafing.

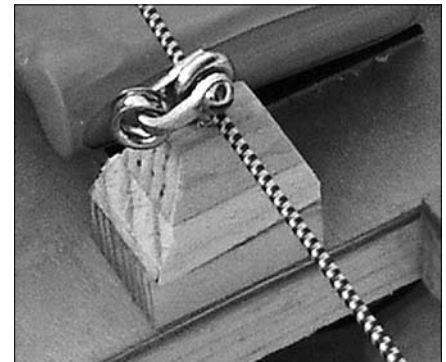
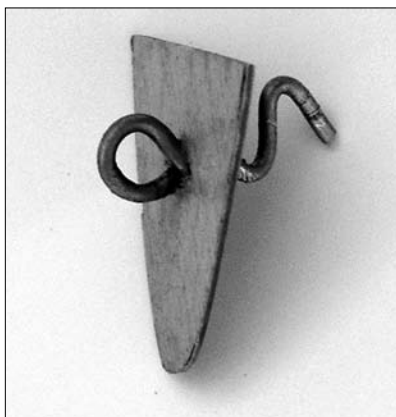


Photo E. The Tensioner Standoff. The screw eye keeps the tensioning elastic properly lined up. That is, it's held down so it doesn't rub against the forward bulkhead and chafe too easily. The shackle and thimble are used to feed the Jib Sheet forward to its fairlead in the bow. Running the Jib Sheet to this point before leading it to the fairlead allows full travel of the Dead-end Ring, from just short of the Turning Block to just short of the Tensioner Standoff (approximately 16 inches—which is way more than enough). Travel adjustment can be made either with your transmitter's ATV or the control pot on your drum winch.



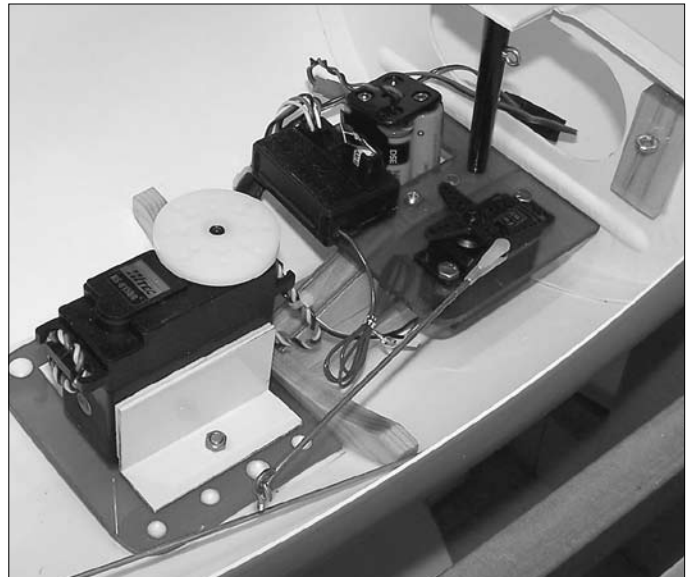
Left: Photo C. The stainless Bow Eye assembly. The eye is bent from 1/16 inch stainless steel rod and mounted in a small, 1/32 inch marine plywood bulkhead that I call a dam (left). Put a few bends in the stainless rod on the bow side of the dam to prevent the eye from pulling out of the epoxy. Right: The eye and dam are positioned in the bow with modeling clay and the "reservoir" is filled with WEST SYSTEM epoxy (West #105 resin and #205 hardener) mixed with Colloidal Silica (West #406) for extra strength. Before pouring the epoxy, rough up the inside of the hull at the bow with 100 grit sandpaper to provide a good bonding surface.



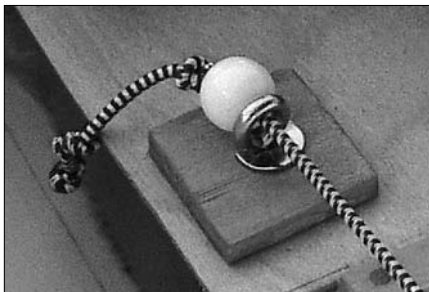
**IMPORTANT:** To maintain proper hull shape, "snap" deck in place and hold with tape while this resin sets.



Photo F. The Rudder Tube Sheave is made from a nylon screen door wheel. The wheel is drilled and shimmed to fit the rudder post.



Above: Photo H. An alternate drum winch arrangement mounted in Perspex (an acrylic sheet product by Lucite), thanks to John Bartram of the New South Wales Radio Yachting Association in Australia. Note how little material (and thus weight) is used to mount the winch, rudder servo, and batteries. Also note the extra material below the mast step and the post, added for stiffening between there and the keel trunk.



Left: Photo G. The Tensioning Elastic terminates at the Elastic Tension Adjuster. As the elastic ages, it tends to lose its strength and needs to be tightened every once in a while. Adjustment is easy with the eye and bead. All you need to do is sheet out all the way, grab the stub end of the elastic, pull the elastic until it's tight again, and tie a new figure eight knot to maintain the new tension. Cut off the excess elastic and you're ready to go.

## 2 "One Design" classes to choose from

### V-32 or Soling One Meter for the ultimate in racing fun

Both models are available as a kit or ready to sail (RTS), which includes an installed top of the line radio system.

#### V-32

AMYA's most colorful one design racing fleet. Over 5300 now sailing worldwide. All colors usually in stock for immediate delivery.

Kit \$95.95    RTS \$324.95

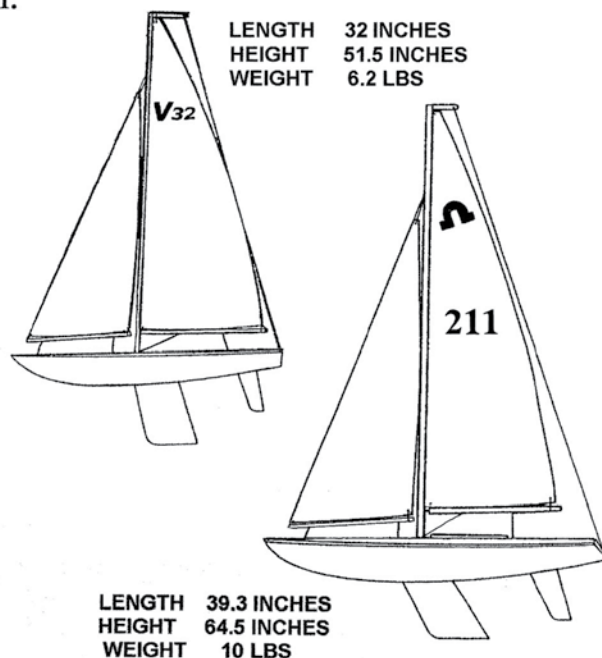
#### Soling IM

AMYA's most popular one design racing class. Kits always in stock. For ready to sail models allow 2 weeks for assembly.

Kit \$125.95    RTS \$550

### **Victor** Model Products

12260 Woodruff Ave., Downey, Ca. 90241  
 Phone (562) 803-1897 Fax (562) 803-1564  
 Visit our website at [victor-model.com](http://victor-model.com)



# ODOM Tips, Tricks and Techniques

From Issue 149

by Bill Mullica

I've built and raced five ODOMs over the last 12 years. These are a few tips, tricks, and techniques that I have picked up along the way.

## Attaching the Fin to the Hull

In order to make the alignment of the fin with respect to the hull adjustable, drill the aft hole through the hull slightly larger than the forward hole. Then insert the fin bolts up through the holes in the hull, slide the keelson block over the bolts on the inside of the hull and thread on the washers and nuts (barely snug—not tight). Now, if you twist the fin, the aft edge will move a small amount from side to side. Use this allowed movement to align the fin precisely with the centerline of the hull. Then tighten the nuts slightly to prevent the keelson block from moving and mark its position on the inside of the hull with a pencil. Now you can remove the fin from the hull and glue (I use Marine-Tex) the keelson block in the correct position shown by the pencil marks.

## Rudder Alignment

Once the fin has been aligned, check to make sure the rudder is vertically aligned with the fin. Insert the rudder post up into the rudder tube and then sight from the aft end of the boat, looking forward. The centerline of the rudder should align perfectly with the centerline of the fin. If it doesn't, adjust the rudder thwart position as necessary to achieve the correct alignment.

## Bulb Weight

The lead bulb that comes with the ODOM kit may be heavier than the class rules allow. The legal weight range is 4 lb. 0.25 oz. to 4 lb. 1.75 oz. Weigh your bulb before attaching it to the keel fin. If the bulb is too heavy, drill some holes in it and fill them with a less dense material (such as epoxy resin) until the weight is within specification. (If you put the bulb in the freezer for several hours, the drilling process will be much easier, and you will be less likely to break a drill bit.)

## Attaching the Bulb to the Fin

It is critical that the bulb be attached to the keel fin so that the two parts are perfectly aligned. Because a single threaded rod is used to make the connection it is possible to adjust the alignment slightly even after the glue has cured. The bottom end of the keel fin is pretty close to the correct 3-degree-up angle as it comes from the factory. To make it possible to adjust it later, sand a slight fore and aft "rocker" in the bottom surface of the fin. Then glue the threaded rod

into the base of the fin and also into the hole in the top of the bulb, making every attempt to align the fin and bulb as precisely as possible before the glue cures. After the glue cures, you can correct any small misalignment by just pushing, pulling, or twisting on the bulb with respect to the fin (bending the threaded rod in the process). When the alignment is correct, apply epoxy putty (for example, Marine-Tex) to the fin-bulb joint to make a small fillet completely around the base of the fin. Smooth the fillet with a wetted finger and allow it to cure completely before wet-sanding with 400 grit wet-or-dry sandpaper (used wet).

## Bulb Finishing

In order to fill imperfections in the bulb surface, mix up some wall spackle to the consistency of a milk shake. Paint the entire bulb with the spackle, let it dry thoroughly and then sand the surface with 220 grit sandpaper. Most of the spackle should be sanded off so the surface is smooth with only the dents, dings, and scratches filled with spackle. Then paint the bulb with one or two coats of epoxy resin (for example, Aerospace Composite Products EZ-LAM 30). You can add color pigment to the resin if desired. When the resin has completely cured, wet-sand with 400 grit (or finer) wet-or-dry sandpaper for a silky smooth surface.

## Reinforcing Hull Cross Members

On some of my previous ODOM hulls, the plywood cross members were fastened to the sides of the hull with small strips of fiberglass cloth and some kind of resin. This resin was quite brittle and could break loose if the hull suffered a shock or sharp blow. To prevent this from happening, reinforce these joints with Goop, E6000, or equivalent. These substances form a semi-flexible but tenacious bond and will not allow the joint to fail during use. Another place for a few drops of Goop is on the inside of the hull all the way forward at the "knuckle" where the stem makes the transition to the bottom of the hull. A small amount of Goop here can prevent water from leaking into the boat if the fiberglass becomes damaged in a collision.

## Screw and Glue

Use wood screws in addition to glue when attaching the sail servo mounts to the internal bulkhead. The sail servo has a lot of torque and can rip the mounts right off the bulkhead if the sheet line gets caught on something

when sheeting in. (Don't ask me how I know.)

## Receiver and Antenna Mount

To keep your receiver high and dry, mount it to the underside of the deck with Velcro. I have found that it is really not necessary to route the antenna through the deck and have it sticking up vertically. Mount the antenna under the deck, and keep it as straight as possible. My antenna runs forward from the hatch on the port side up to the bow and then back along the starboard side. I've never had any reception problems, and I have one less hull penetration.



Figure 1. Single pulley block on sail servo arm. All photos by Bill Mullica.

## Low Friction Sail Servo Arm

In light wind conditions there is not much pressure on the sails. If there is a lot of friction where the sheet line travels through the end of the sail servo arm, the sails will not move out. To minimize friction use a single pulley block (SAILSetc item #61a) on the end of the servo arm. In my case, I modified and used the arm that came with my Hitec HS-815BB servo, so I just cut a slot in the end of the arm, inserted the pulley block, and then filled the slot with Goop. (See Figure 1.)

## Fully Adjustable Foredeck

I like to be able to change the mast step position and mast rake with varying wind conditions. As the mast moves forward or aft, I need to be able to change the jib swivel position and jib sheet fairlead position accordingly. I accomplish this by mounting an aluminum deck track (SAILSetc item #28-330) on the foredeck. A track slide with eyebolt (SAILSetc item #38b) is used to position the jib swivel, and one is also used as the jib sheet fairlead. Each has a setscrew that is used to secure the eyebolt at any position along the length of the track. My jib swivel eyebolt has a thumbscrew for easier adjustment (SAILSetc Item #38c), but these may be available only from SAILSetc directly. The track must be long enough to posi-

tion the jib swivel eyebolt as far forward as will be necessary (heavy wind conditions) and also to position the jib sheet fairlead eyebolt as far aft as will be necessary (light wind conditions). (See Figures 2 and 4.) The track is fastened to the deck with small machine screws. The deck should be reinforced underneath to support the track, and I strongly recommend a “hard point” near the forward end of the track where the jib swivel will be positioned. Blind nuts under the deck make it easy to secure the deck track and to remove it at a later time if necessary.



Figure 2. Jib attachment to foredeck track.

On my rig, the jib swivel is just a short piece of 30 lb. test Dacron line. The free end has a small overhand loop tied in it. A third track slide with eyebolt slides freely between the jib swivel eyebolt and the jib sheet fairlead eyebolt. (See Figure 2.) The setscrew is removed from this track slide since it is never needed. I attach my jib to the deck track by threading the free end of the jib swivel line through the jib swivel eyebolt (from forward to aft) and then looping it over (not through) the free-sliding eyebolt.

Tension on the jib swivel will pull the free-sliding eyebolt forward until it butts up against the forward eyebolt and will keep the line from coming off when sailing. If I need to adjust the jib swivel position between races, I just loosen the setscrew on the forward eyebolt and slide it wherever I want it—the free sliding eyebolt moves with it due to rig tension. (See Figure 3.)



Figure 3. Adjustable jib swivel position.

Then I adjust the position of the jib sheet fairlead eyebolt so that it is directly under the sheet attachment point on the boom. (See Figure 4.) I put a piece of tape over the aft end of

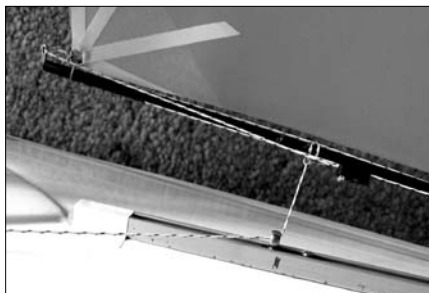


Figure 4. Adjustable jib sheet position.

the track so the jib sheet will not catch on it.

After these adjustments, the jib sheet length will probably need to be adjusted as well. (To see how to do this, read my ODOM rig article in this issue of *Model Yachting*.) You can also make semi-permanent changes in the rake of the mast by inserting a spacer (wood dowel or carbon fiber tubing) in the deck track between the forward eyebolt and the free sliding eyebolt. (See Figure 5.) Using a longer spacer will move the jib down closer to the deck and move the top of the mast forward (heavy wind setup). Using a shorter spacer will move the jib up and move the top of the mast aft (light wind setup).



Figure 5. Free sliding eyebolt with spacer.

### External On/Off Switch

*In order to minimize leaks, many ODOM sailors tape the hatch cover down or use a sticky Dacron patch to cover the hatch opening. This makes it very difficult to turn the power on and off if the switch or plug is inside the hull. Try mounting a waterproof toggle switch (SAILSetc item #SWB) through the deck. Make sure to choose a location where a sheet line cannot accidentally loop over the toggle and turn the power off! (Again, don't ask me how I know.) I have a piano-wire “bridle” that holds the mainsheet above the deck. I mount my on/off switch directly underneath the bridle to keep it clear of the sheet. (See Figure 6.)*

### Adjustable Mainsheet Position

On many ODOMs, the mainsheet pulls more in a downward direction than inward when the sails are close hauled. This limits how close the mainsail can be sheeted in and also tends to add tension to the mainsail leech, reducing twist. To allow the mainsheet to pull horizontally, not vertically, the sheet must be raised to a position just below the main boom.



Figure 6. Waterproof switch and mainsheet bridle.

It should also be adjustable fore and aft to match the mast step position and be simple, light, and foolproof. I made a “bridle” of piano wire and a PTFE (Teflon) ring (SAILSetc item #53). The wire is bent to an inverted V-shape so that the top of the V is just below the main boom. The ends of the wire are bent back approximately 135 degrees and inserted through small 1/16 in. diameter holes drilled at the edges of the deck. Add a small drop of Goop or silicone to seal the holes. The ring is lashed to the wire at the midpoint with line and then sealed with glue. Another line extends aft from the ring to the backstay fitting at the transom and is looped through a bowsie for adjustability. The mainsheet is threaded through the ring and then run forward. The balance of the mainsheet tension pulling forward and the line to the transom pulling aft keeps the ring centered directly below the boom at the sheet attachment point. Adjust the bowsie to maintain this position as the mast step position changes. (See Figure 7.)

### Single Hull Penetration for Sheets

Because both the mainsheet lead and the jib sheet lead are on top of the deck, only a single hull penetration is needed to connect the sheets to the sail servo. I use a 180-degree sheet fairlead (SAILSetc item #60a) located aft near the lazarette. The exit tube is small and above deck level, which reduces the amount of water entering the boat. (See Figures 8 and 6.)

The sail servo needs only one arm and is positioned such that the arm is pointing almost directly away from the sheet fairlead when the sails are close hauled. (See Figure 9.) This means the perpendicular component of the force on the servo arm is very small, and the servo can hold this position with minimum drain on the battery.

It is important to achieve nearly 180-degree rotation in the servo arm as well. More rotation means you can reduce the length of the arm and get the same amount of sheet travel. For a given available torque, a shorter arm means more pulling force on the sheets.

The outside end of the sheet is terminated on the deck with a simple swivel snap from the





Figure 7. Adjustable mainsheet position.



Figure 8. One hundred eighty degree sheet fairlead.



Figure 9. Sail servo close-hauled.

local fishing store. I cut off the swivel part, tie on the snap connector, and secure it with cyanoacrylate (CA) adhesive. (See Figure 10.) A length of rubber band is tied or looped over the “hook” part of the snap connector, threaded through a small eyebolt on the deck, and then attached to the deck as far forward on the deck as possible. (See Figure 11.) (I actually run the

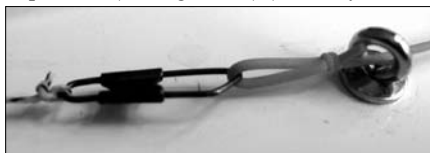


Figure 10. Snap connector.

rubber band through a small eyebolt at the bow and then attach it to the chain plate on the opposite side of the deck.) The rubber band just takes the slack out of the sheet line as the servo arm moves to the “full out” sail position.



Figure 11. Single sheet line, snap connector, and rubber band.

In operation, the snap connector just moves forward and aft along the top of the deck. The total travel on mine is about 9-1/4 inches. The small eyebolt is used as the “turning point” (fairlead) for the sheets. The mainsheet is threaded through the ring on the bridle (from top to bottom) and then through the eyebolt on the deck (from forward to aft). The jib sheet is threaded through the jib sheet fairlead (from forward to aft) and then through the deck eyebolt (from forward to aft). Both sheet lines are terminated at the snap connector to complete the hookup to the sail servo.

#### Remove Rudder Easily

To make the rudder easily removable for travel, install a tiller arm (SAILSetc item #68c) with the setscrew facing aft. Replace the standard setscrew with a socket-head cap screw and get a long ball driver to fit the setscrew. (See Figure 12.)

Drill a small hole in the transom and use the ball driver (inserted through the hole) to tighten or loosen the setscrew on the tiller arm. (See Figure 13.) Cover the hole with a small piece of tape

to keep out the water. To prevent twisting of the tiller arm on the rudder shaft, file a flat spot in the rudder shaft where the setscrew meets it.

#### Tape the Deck?

On my first ODOM, I attached the deck to the hull with glue. I didn’t want to use too much glue because it would be heavy and messy. When I was done, I was concerned that the joint might not be totally watertight, so I taped over the joint with 3/4-in. 3M Plastic Tape. It is available from your local hardware store and comes in several colors, including clear. It looked good and worked fine. Ever since then, I have just skipped the gluing part and attached the deck to the hull with screws and tape only. This also gives me the ability to remove the tape later to



Figure 12. Modified tiller arm.

get inside to boat for emergency repairs.

First the deck is attached to the hull with screws at the “hard points” (jib swivel, mast step, and chain plates). Then a continuous length of tape is applied to the hull, beginning at the bow and extending all the way to the stern. Half of the tape width (3/8 in.) is stuck to the side of the hull, while the other half is left sticking up vertically at the gunwales. Gradually work around the edge of the deck, pressing the deck down firmly and “rolling” the tape over the joint and onto the deck with your thumb. After both sides of the deck have been taped down in this manner, cut a short length of tape and apply it to the deck joint at the

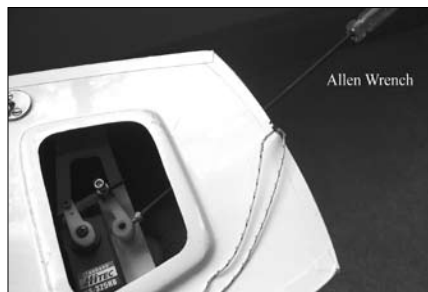


Figure 13. Use ball driver to tighten or loosen tiller arm.

transom to complete the job. Works for me!

#### Topping Lift Fitting

I’m not particularly crazy about the aluminum V-shaped topping lift fitting offered by GRP. My main complaint is that it distorts the headstay when there is tension on the topping lift line. It is also heavier than it needs to be and has considerable windage. I made my own

# RMD Marine

Home of the Original One Piece EC-12 Hull

## All Cloth – No Mat • No Seam (No Leak)

Hull: \$250.00 One Piece, One Color (No Seam)

Deck: \$130.00 Gelcoated, Standard Colors F/G-Foam Composite — Installed 11-13 ozs

Rudder: \$85.00 Gelcoat/Epoxy Composite (It floats)

Ballast: \$90.00 18 lb 6 oz Plus (Fits keel pocket perfectly)

## Will Build to Any Stage of Completion • Price On Request

Prices subject to change with notice – Packing and shipping charges extra

Email: [RMDmarine@tampabay.rr.com](mailto:RMDmarine@tampabay.rr.com) • Phone: 727-360-4193



version from an 8 in. piece of music (piano) wire. I bent the wire into the shape of a pennant. (See Figure 14.)

The first bend is 1-1/2 in. from one end (the starting end) of the wire and is about 160 degrees. The second bend is 1-1/2 in. from the first and is about 100 degrees. After these two bends, the starting end of the wire should be touching the long, 5 in. straight piece (the base). If it isn't, adjust the bends as necessary until the starting end just touches the base and solder the starting end to the base at this point. The solder joint should be about 3/4 in. from the second bend. Now make a third, 180-degree bend as close to the bottom of the base as you can. This last bend will create a small "hook" at the bottom end of the base and is used to attach the headstay to the topping lift fitting. The hook is not visible in the photo since it is actually down inside the luff pocket of the jib. The upper part of the fitting is attached to the masthead crane with line (e.g. 30 lb. braided Dacron). The topping lift line itself is attached to the tip of the pennant as shown in the photo. This makes the topping lift line stand off from the headstay far enough for the line to clear the roach on the sail. Another line with a bowsie is attached to the head of the jib and loops up and through the topping lift

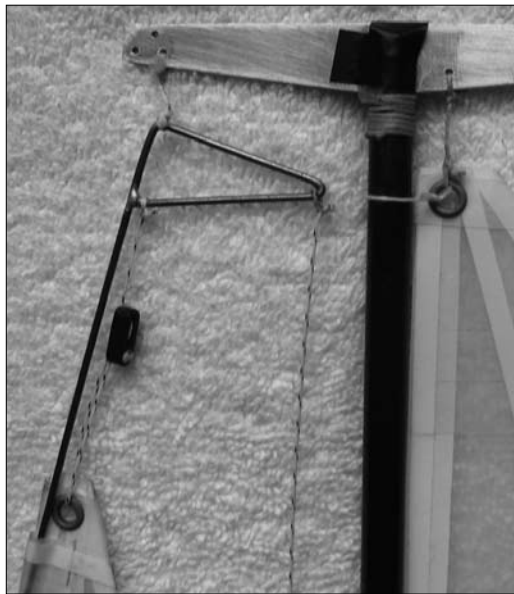


Figure 14. Music-wire topping lift fitting.

fitting. This line is used to adjust jib luff tension.

On my rig, the distance from the top of the jib to the bottom of the masthead crane is 3-1/2 inches. If you don't have this amount of space, shorten the jib swivel to move the sail closer to the foredeck. If necessary, trim off some of the foot round on the bottom of the jib and slide the sail down the headstay, closer to the boom. (I trimmed about 3/4 in.

off of mine.)

## Center the Mast

To perfectly center your mast so that it is directly in line with the keel fin, rig your boat and lay it on its side on a flat surface. Then measure the distance from the surface to the top of the mast. Turn the boat over and lay it on the other side. Measure the distance from the mast top to the surface again. Adjust the shrouds as necessary until the top of the mast is the same distance above the surface on both sides. Voilà! Your mast is centered. Many thanks to Bob Sterne for this tip.

## Bundle Those Wires

Use a small cable tie or twist tie from the grocery store to bundle up the electrical wires inside your boat. Keep them as high and dry as possible. (See Figure 1.)

## Electrical Wire Splices and Connections

Instead of wrapping electrical wire splices or soldered connections with electrical tape or shrink-wrap, use a large drop of Goop or E6000. Wet your fingers to avoid sticking while you shape the Goop around the wire or connection. Check and reshape as necessary over the following 15 to 30 minutes. Let the Goop cure completely to form a waterproof, insulating, strain-relieving, and clear-visibility coating over the connection.

*"fast service, faster boats and equipment"*



## www.isobaryachts.com

Online Store | Yachts | Booms | Masts  
Fittings | Sails | Winches | Fins | Rudders

(484) 679-1270 | [todd@isobaryachts.com](mailto:todd@isobaryachts.com)

VISA | MasterCard | Discover | Amex



# Sail away with advice from the experts

**SUBSCRIBE**  
from just \$16.50\*

THE IDEAL MAGAZINE FOR ALL MODEL SAIL BOAT ENTHUSIASTS, COVERING ALL FORMS OF MODEL SHIP AND BOAT BUILDING AND SAILING. REGULAR MONTHLY SLOTS FOR TOP RACING AND SPORT SAILING BOATS.

## INCLUDES:

- FREE PLANS
- MONTHLY R/C SAILBOAT COLUMN AND FEATURES
- REGULAR FOCUS FILE FEATURES
- KIT REVIEWS
- FEATURE ARTICLES
- TECHNICAL ADVICE
- HELPFUL TIPS

## DVD's



### R/C RACING SKIPPER

Join Chris Jackson editor of Marine Modelling International magazine at five championship events as he examines the boats, the technology and the tactics used by top competition skippers as they battle for success.

Featuring the following different yacht classes:

- R/C Laser
- International One Meter (IOM)
- Marblehead
- Ten-Rater
- RA Class

APPROX. 80 MINUTES  
DVD REF: DV506 VIDEO REF: VW506 **\$19.95 + S&H**



### MARVELLOUS MARBLEHEADS!

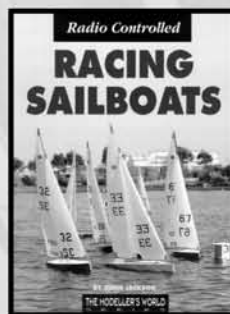
Chris Jackson, editor of Marine Modelling International, takes an in-depth look at these modern, high performance craft.

Featuring:

- Highlights of the World Championships
- Tactics & technology used by top skippers
- Hot tips on rig set up & timing
- Interviews & discussions with designers, skippers and umpires
- **BONUS FOOTAGE OF PURE MARBLEHEAD ACTION!**

APPROX. 30 MINUTES  
DVD REF: DV504 VIDEO REF: VW504 **\$24.95 + S&H**

## Books



### RADIO CONTROLLED RACING SAILBOATS

BY CHRIS JACKSON

Discover everything you need to know about radio controlled racing sailboats. Aimed the newcomer, but with much to interest the experienced competitor, this book provides invaluable information.

Featuring:

- Basic sailing theory
- Building methods for hulls, sails and rigs
- Design and construction of foils,
- radio gear and winches
- Racing strategy

REF: RCRS **\$24.00 + S&H**



### MARINE MODELLING INTERNATIONAL PLANS & CONSTRUCTION GUIDE

A unique source of over 200 plans to buy and build today. Plans include: Racing Sailboats, One Meters, Marbleheads, Ten Raters, Multihulls and Scale Sailboats – each illustrated with photos and a link to the relevant back issue article.

REF: MMPGD6 **\$6.95 + S&H**

**INCLUDES \$30**  
WORTH OF PLAN DISCOUNT VOUCHERS

# PLACE YOUR ORDER TODAY!

**TEL: 217 355 2970 FAX: (001) 217 351 4135**

**WEBSITE: WWW.TRAPLET.COM**

**SEND CHECK OR MONEY ORDER TO:**

**TRAPLET DISTRIBUTION USA LTD., P.O. BOX 6178, CHAMPAIGN, IL 61826, USA.**

S&H PER VIDEO/DVD: \$6.00 ● S&H PER BOOK: \$6.50 ● S&H PER PLANS GUIDE: \$4.00

\*USA 3 ISSUE SUBSCRIPTION (ILLINOIS RESIDENTS ADD 7.5% SALES TAX)

ALL PRICES CORRECT AT THE TIME OF GOING TO PRESS AND MAY BE SUBJECT TO CHANGE WITHOUT FURTHER NOTIFICATION

TO RECEIVE A FREE COPY OF OUR CURRENT MODELING CATALOG CONTACT US TODAY!



### YOUR ORDER MUST CONTAIN:

- MAGAZINE OR DVD/VIDEO TITLE
- MAGAZINE SUBSCRIPTION LENGTH
- NAME ADDRESS AND PHONE NUMBER (WITH AREA CODE) FOR DELIVERY
- YOUR PAYMENT/PAYMENT DETAILS (WE ACCEPT ALL MAJOR CREDIT CARDS)

# AMYA Stats & Facts



Michelle Dannenhoffer,  
Membership Secretary,  
membership@modelyacht.org

The table shows the class populations as of July 13, 2007. This is a direct output from the AMYA membership database.

The table lists members reporting ownership in a particular class, not the actual number of boats registered.

There has been slight growth in population since the last issue, beyond staggered membership renewals. We need more new members, and we need them to register their boats. *It is important for your class (and to protect your investment) that you remember to list at least one hull/sail number for each class of model yacht you own when you complete your AMYA Membership Renewal form.*

I send each member a membership renewal form 90 days in advance of when that membership expires. Often, many of your boats are already listed on that form. This listing is critical for new classes seeking AMYA sanction, for classes with membership close to the minimum twenty AMYA registered members/owners, and for all classes to determine their condition. Check what is listed, and add any boats missing. It really helps your classes remain strong, and *it is vital to have your listing complete*—please do so. When sending any payment to me for the AMYA, *please do not send cash.*

If you have not yet registered your model yacht, fill in the Yacht Registration Form (below), and send it with the registration fee directly to your Class Secretary (address listed on the Masthead on page 4). *Please do not send cash* for payment.

All racing is “local,” and the class your club races is what is important to you. These numbers indicate National and Regional numbers of skippers and can be helpful for clubs looking for a new class to sponsor that is also popular in their region—this builds regional regatta participation and great local racing.

## Class Members (not boats) by Region 2 January 2008

	Total	R-1	R-2	R-3	R-4	R-5	R-6
Soling One Meter	754	140	32	316	129	40	97
EC12	405	54	65	181	52	24	29
Victoria	347	20	42	88	59	80	57
US One Meter	275	55	13	40	62	16	89
Marblehead	239	28	47	31	35	36	62
ODOM	213	14	34	10	28	19	108
CR914	172	42	29	29	18	23	31
IOM	154	22	11	16	16	28	61
36/600	144	11	24	28	22	37	22
Sea Wind	122	16	8	28	16	32	22
Santa Barbara	106	8	2	7	28	6	55
Star 45	106	19	4	15	33	20	25
V-32	103	2	4	11	35	9	42
Soling 50	96	2	3	7	2	4	78
Open	95	11	12	31	24	8	9
Footy	91	18	9	24	15	12	13
US12	82	14	4	50	8	3	3
Fairwind 900	74	10	0	15	30	4	15
R/C Laser	61	13	4	11	14	10	9
Newport 12	54	1	1	1	1	5	44
AC Class	47	8	3	2	17	8	9
J Class	38	12	6	5	5	4	6
10 Rater	26	2	4	0	0	13	7
Infinity 54	26	1	0	0	3	2	20
Wheeler	24	5	3	2	1	1	12
Traditional 36	23	3	15	2	3	0	0

## AMYA Yacht Registration Form

Use this form for registering a new yacht or transferring ownership of an already-registered yacht. Send the completed form to the AMYA Class Secretary or Class Owners' Association with a check or money order for \$7, payable to the Class Secretary *personally* by name rather than title.

Name: \_\_\_\_\_ AMYA No. (required): \_\_\_\_\_

Address: \_\_\_\_\_

City: \_\_\_\_\_ State: \_\_\_\_\_ Zip: \_\_\_\_\_

Phone: \_\_\_\_\_ E-mail: \_\_\_\_\_

Club: \_\_\_\_\_ Class: \_\_\_\_\_

If Transfer, Existing Sail No: \_\_\_\_\_ Manufacturer: \_\_\_\_\_

Manufacturer's Hull/Serial No. (if any): \_\_\_\_\_

**\$7**

**The American Model Yachting Association's Ships Store Catalog: 10/2007**

ITEM	DESCRIPTION OF ITEM	COST EACH	TOTAL COST	SHIP'S STORE
<b>PUBLICATIONS</b>				
1	Reprint Book How to articles from past issues of M.Y. 68 pages	9.50		
2	Organizing Club & Conducting a Regatta Detailed treatise for Clubs. Matrix & Race Schedules. 65 pgs by Dick Hein	10.00		
3	<b>In Stock:</b> Magazine Back Issues <b>Please Circle Number(s) wanted</b> 94, 95, 97, 98, 99, 100, 101, 103, 108, 112, 113 > 119, 122, 123, 125, 126, 127, 128, 130, 131, 132, 133, 134, 135 > 136, 137, 138, 139, 140 141, 142, 143, 144, 145, 146, 147, 148, 149 >	6.00 7.00 7.00		
	<b>Magazine Class Boat Combo's</b>  <b>Please Circle item(s) wanted</b> Victoria Issue 112 & 132 Getting Started I & II Issue 130 & 146 Vintage Class Issue 96 & 122, EC12 Class Issue 115 & 145, 36/600 Class Issue 116 & 147 ODOM Issue 99 & 124, Santa Barbara Issue 117 & 147, Soling One Meter Issue 120 & 148 IOM Class Issue 107 & 114	10.95 11.95 15.95 15.95 19.95		
	<b>Out of Print Reprints</b> Magazine Back Issues 40, 41, 42, 43, 44, 45, 46, 47 48, 49, 50, 51, 52, 53/54, 55 56, 57, 58, 59, 60 , 61, 62, 63, 64, 65 > 66, 67, 68, 69, 70, 71, 72, 73, 74, 75, 76, 77, 78, 79, 80, 81,82, 83, 84, 85, 86, 87, 88, 89, 90, 91, > 92, 93, 96, 102, 104, 105, 106, 107, 109, 110, 111, 114, 115, 116, 117, 118, 120, 121, 124, 129 >	12.00 12.00 12.00		
4	Racing Rule Book The Racing Rules of Sailing – US Sailing Prescriptions Non-Members + 1.50 S/H	15.00		
5	Racing Rule Book The Racing Rules of Sailing –US Sailing Prescriptions Members + 1.50 S/H	12.00		
6	Quarterly Newsletter AMYA 1970 – 1975 Compiled Quarterly Newsletters (Issue #1 through #22) - 456 Pages	25.00		
<b>MODEL YACHT PLANS</b>				
7	50/800 Marblehead Class -Bone 1X	30.00		
8	Star 45 Star 45 Class	18.00		
9	36/600 <b>(Please Circle Which One)</b> Blimp or Diegan	10.00		
10	AC Class <b>(Please Circle Which One)</b> Bahamut or Leviathan or Boogieman	18.00		
11	Window Decal AMYA Logo Decal 3 1/2 x 4 1/2	4.50		
12	Sail # & Class Emblem 3"Hx1/2"W Vinyl Each Number or Emblem is 1.00 each. Sail # _____ Class Emblem _____ Colors Available: Black, Blue, Green, Red, Yellow	1.00		
13	Race Starting Tape Starting Tape with One & Two Minute Warning	7.00		
14	Race Starting CD <b>(Please Circle Which One)</b> CD with Two Minute or One Minute Warning	7.00		
15	Patch AMYA logo embroidered in 3 colors on white. Suitable for shoulder, jacket or shirt. 3" x 4"	5.00		
16	Lapel Pin AMYA logo 4 colors 7/8 x 1/2 inches	5.00		
17	Bumper Sticker AMYA logo w/ I'd Rather Be Sailing My R/C Model Yacht Blue ink on white vinyl 9" x 3 "	1.00		
18	Jerzee 50/50 Polo Shirts  White, Black, Gold, Orange, Red, Royal Blue, Grey, Navy, Green (Sm-4X) With/Without Pocket	23.95		
19	AMYA Sandwich Bill Hat  AMYA Logo Self Fabric Closure w/Brass Buckle Royal Blue/White, Red/Black, Maroon/White, White/Navy, Navy/Khaki	12.95		
		<b>TOTAL</b>		

AMERICAN EXPRESS/DISCOVER/ VISA/MASTERCARD # \_\_\_\_\_ Expiration Date \_\_\_\_/\_\_\_\_/\_\_\_\_

If Paying By Check, Please Make Payable To AMYA ALL FUNDS IN US DOLLARS ONLY.

\*\*\*\*\* PLUS FOR SHIPPING & HANDLING \*\*\*\*\*

(\$0.01-\$12.00 - USD-\$3.00) (\$12.00 -\$49.99 USD-\$6.00) (\$50.00-\$99.99 USD-\$8.00) (\$100.00- \$199.99 USD-\$10.00) (\$200.00– UP-\$15.00)

Ship To:	<i>Please Print</i>	AMYA #
NAME	E-Mail Address:	
ADDRESS	CITY	
STATE	ZIP	PHONE

**NOTICE: WE DO NOT SELL MEMBERSHIP LISTS FOR COMMERCIAL USE. NO RETURNS, NO REFUNDS ON ITEMS SHIPPED.**

**Send To: A.M.Y.A. Ship's Store** Please state Club Name and AMYA Club Number to qualify for discounted prices:

C/O Michelle Dannenhoffer

P. O. Box 360374

Melbourne, FL 32936-0374

(800) 420 - 3048

Club Rule Book Discounts: 15 - 25 @ \$11.00 each. 25 or more @ \$10.00 each.

Club Lapel Pins Discounts: @ \$3.00 each, with minimum order of 20 pins=fundraisers.

**In Stock Back Issues:** At least 4 magazines: \$6 ea. 5-10: \$5 ea. 11 or more: \$4ea.

**Visit The New Online** [www.shipsstoremodelyacht.com](http://www.shipsstoremodelyacht.com)

# AMYA Membership Form

This application is for (please circle one): **New Membership**      **Renewal/Former**

Please enter your membership number, if known for a Renewal/Former Member: \_\_\_\_\_

**Contact Information:** Please print or type your contact information:

Name \_\_\_\_\_

Address \_\_\_\_\_

City \_\_\_\_\_ State \_\_\_\_\_ ZIP \_\_\_\_\_ - \_\_\_\_\_

Country \_\_\_\_\_

Telephone \_\_\_\_\_

E-Mail \_\_\_\_\_

**Types of Membership:** Membership in the American Model Yachting Association (AMYA) is open to anyone who shares the goals of the organization. **Adult** membership includes Model Yachting magazine, eligibility for registration of model yachts in AMYA Sanctioned Classes, eligibility for entry into AMYA championships and other sanctioned events, one vote in the affairs of the organization and classes, and other benefits. **Family** membership provides a single Adult membership and eligibility in AMYA sanctioned events for all family members the same household. **Junior** membership is available to applicants under 19 years of age, but is otherwise identical to an Adult membership.

<b>ADULT</b>	<b>\$25.00</b>	<input type="checkbox"/>	<b>Membership</b>
<b>FAMILY</b>	<b>\$27.50</b>	<input type="checkbox"/>	
<b>JUNIOR</b> Enter Birth Date: _____	<b>\$12.50</b>	<input type="checkbox"/>	

**Postage:** Normal Fourth Class delivery of Model Yachting magazine takes 4 to 8 weeks. **For faster delivery**, members residing in the United States may select USA First Class Postage Option. Members residing outside the USA must include an additional fee to cover the costs of mailing.

“Snowbirds” Secondary Address (Requires USA First Class Postage Option): \_\_\_\_\_

Secondary Address Start Date: \_\_\_\_\_ (mm/dd/yyyy)      Return to Primary Address Date: \_\_\_\_\_ (mm/dd/yyyy)

<b>USA FIRST CLASS OPTION</b>	<i>Snowbirds Must Include</i>	<b>\$10.00</b>	<input type="checkbox"/>	<b>Additional Postage</b>
<b>CANADIAN POSTAGE</b>	<i>Must include</i>	<b>\$10.00</b>	<input type="checkbox"/>	
<b>ALL OTHER COUNTRIES</b>	<i>Must include</i>	<b>\$15.00</b>	<input type="checkbox"/>	
<b>Total</b>			<input type="checkbox"/>	<b>Membership + Addl Postage</b>

You may renew by phone or email with a credit card. For checks and money orders, please fill out this form and return it with your funds, payable to “AMYA” to the Membership Secretary. Individual model yacht registration applications are made directly to the Class Secretary of your AMYA Sanctioned Class. An AMYA Yacht Registration Form is in the magazine. All funds must be in US dollars drawn on a US bank; **do not send cash.**

**Credit Card Info:** Please circle one:      **MC**      **VISA**      **DISCOVER**      **AMEX**

CARD NUMBER \_\_\_\_\_ - \_\_\_\_\_ - \_\_\_\_\_ - \_\_\_\_\_      EXPIRATION \_\_\_\_\_ - \_\_\_\_\_

SIGNATURE \_\_\_\_\_

**Your Club:** If you are a member of an AMYA Sanctioned Club, please enter your Club’s AMYA Number and your Club’s Name here:

CLUB NUMBER: \_\_\_\_\_ CLUB NAME: \_\_\_\_\_

Send your completed form to:

**AMYA Membership Secretary**  
**Michelle Dannenhoffer**  
**P.O. Box 360374**  
**Melbourne, FL 32936**

Toll Free Phone: 888-237-9524

E-Mail: [Membership@ModelYacht.org](mailto:Membership@ModelYacht.org)